

HAR[®] 379x

Robust Dual-Die Programmable
2D Position Sensor Family
with PWM/SENT Output



Copyright, Warranty, and Limitation of Liability

The information and data contained in this document are believed to be accurate and reliable. The software and proprietary information contained therein may be protected by copyright, patent, trademark and/or other intellectual property rights of TDK-Micronas. All rights not expressly granted remain reserved by TDK-Micronas.

TDK-Micronas assumes no liability for errors and gives no warranty representation or guarantee regarding the suitability of its products for any particular purpose due to these specifications.

By this publication, TDK-Micronas does not assume responsibility for patent infringements or other rights of third parties which may result from its use. Commercial conditions, product availability and delivery are exclusively subject to the respective order confirmation.

Any information and data which may be provided in the document can and do vary in different applications and actual performance may vary over time.

All operating parameters must be validated for each customer application by customers' technical experts. Any new issue of this document invalidates previous issues. TDK-Micronas reserves the right to review this document and to make changes to the document's content at any time without obligation to notify any person or entity of such revision or changes. For further advice please contact us directly.

Do not use our products in life-supporting systems, military, aviation and aerospace applications! Unless explicitly agreed to otherwise in writing between the parties, TDK-Micronas' products are not designed, intended or authorized for use as components in systems intended for surgical implants into the body, or other applications intended to support or sustain life, or for any other application in which the failure of the product could create a situation where personal injury or death could occur.

No part of this publication may be reproduced, photocopied, stored on a retrieval system or transmitted without the express written consent of TDK-Micronas.

TDK-Micronas Trademarks

- HAL
- HAR
- 3D HAL

Third-Party Trademarks

All other brand and product names or company names may be trademarks of their respective companies.

Contents

Page	Section	Title
5	1.	Introduction
6	1.1.	Major Applications
7	1.2.	Main Features
8	2.	Ordering Information
8	2.1.	Device-Specific Ordering Codes
9	3.	Functional Description
9	3.1.	General Function
10	3.2.	Signal Path
11	3.3.	Register Definition
11	3.3.1.	RAM Registers
14	3.3.2.	EEPROM Registers
22	3.4.	Output Linearization
24	3.5.	On-Board Diagnostic Features
26	3.6.	SENT Output Protocol
26	3.6.1.	6 Data Nibble Frame with Two Fast Channels (H.1 Format SAEJ2716 rev. 4)
27	3.6.2.	3 Data Nibble Frame with One Fast Channel (H.2 Format SAEJ2716 rev. 4)
27	3.6.3.	6 Data Nibble Frame with Secure Information (H.4 Format SAEJ2716 rev. 4)
28	3.6.4.	Error Diagnostic Reporting on Fast Channel
29	3.6.4.1.	Impact of Diagnosis Bit (CUST_SETUP1 - bit 1) on SENT Output
30	3.6.5.	Timing of Error Reporting on Fast Channel
30	3.6.6.	Pause Pulse
30	3.6.7.	CRC Implementation
30	3.6.8.	Slow Channel: Enhanced Serial Message
31	3.6.9.	Slow Channel: Serial Message Sequence
32	3.6.10.	Slow Channel: Serial Message Error Codes
33	3.6.11.	Slow Channel: Sensor Types
33	3.6.12.	Start-Up Behavior
34	3.6.13.	Message Time for SENT Frames with Pause Pulse
36	4.	Specifications
36	4.1.	Outline Dimensions
37	4.2.	Soldering, Welding, Assembly
37	4.3.	Storage and Shelf Life Package
37	4.4.	Size of Sensitive Area
37	4.5.	Definition of Magnetic-Field Vectors
38	4.6.	Pin Connections and Short Description
39	4.7.	Absolute Maximum Ratings
40	4.8.	Recommended Operating Conditions
41	4.9.	Characteristics
45	4.10.	Magnetic Characteristics

Contents, continued

Page	Section	Title
47	5.	Application Notes
47	5.1.	Ambient Temperature
47	5.2.	EMC and ESD
48	5.3.	Application Circuits
50	5.4.	Measurement of a PWM Output Signal
51	6.	Programming of the Sensor
51	6.1.	Programming Interface
52	6.2.	Programming Environment and Tools
52	6.3.	Programming Information
53	7.	Document History

Robust Dual-Die Programmable 2D Position Sensor Family with PWM/SENT Output

Release Note: Revision bars indicate significant changes to the previous edition.

1. Introduction

HAR 379x is the fully redundant (dual-die) version of the HAC 37xy family using TDK-Micronas' proprietary 3D HAL[®] technology. It provides full redundancy due to two independent dies stacked in a single package bonded on different sides of the package. The stacked-die architecture ensures that both dies occupy the same magnetic field position, thus generating synchronous measurement outputs.

HAR 379x features digital output formats PWM and SENT according SAEJ2716 standard. The digital output format is customer programmable. In SENT mode, the sensor transmits SENT messages with and without pause pulse according to SAEJ2716 rev. 4. The PWM output is configurable with frequencies between 0.2 kHz and 2 kHz with up to 12 bit resolution.

Conventional planar Hall technology is only sensitive to the magnetic field orthogonal to the chip surface. In addition to the orthogonal magnetic field, HAR 379x is also sensitive to magnetic fields applied in parallel to the chip surface. This is possible by integrating vertical Hall plates into the standard CMOS process.

The sensor cell can measure three magnetic field components B_x , B_y , and B_z . This enables a new set of applications for position detection, like wide distance, angle or through-shaft angular measurements.

Table 1–1: HAR 379x family members

Type	Detectable Field Component
HAR 3795	B_x and B_y
HAR 3796	B_y and B_z
HAR 3797	B_x and B_z

On-chip signal processing calculates the angle out of two magnetic-field components and converts this value to an output signal. Due to the measurement method, the sensor exhibits excellent drift performance over the specified temperature range resulting in a new class of accuracy for angular or linear measurements.

Additionally to the built-in signal processing, the sensor features an arbitrary programmable linear characteristic for linearization of the output signal (with up to 33 setpoints).

Major characteristics like gain and temperature dependent offset of X- and Z-channel, reference position, phase shift between X- and Z-signal, hysteresis, low-pass filter frequency, output slope, and offset and clamping levels can be adjusted to the magnetic circuitry by programming the non-volatile memory.

The sensor contains advanced on-board diagnostic features that enhance fail-safe detection. In addition to standard checks, such as overvoltage and undervoltage detection as well as wire breaks, internal blocks such as ROM and signal path are monitored during normal operation. For devices with a selected PWM output, the error modes are indicated by changing PWM frequency and duty-cycle. For SENT output a dedicated error code will be transmitted.

The devices are designed for automotive and industrial applications.

The sensors are available in a very small eight-pin SOIC8 package.

1.1. Major Applications

Thanks to its redundancy capability, HAR 379x can address safety-critical applications according to ISO 26262 rules. The sensor's versatile programming characteristics and its high accuracy, make the HAR 379x the optimal system solution for applications such as:

- Linear movement measurement,
 - Dual-Clutch transmission
 - Clutch pedal position
 - Engine stroke sensor
 - Transmission position
 - Cylinder and valve position sensing
 - Rear-axis steering
- Rotary position measurement, like
 - Gear selector
 - Throttle valve position, etc.
- Non-contact potentiometer

1.2. Main Features

- Angular and position measurement extremely robust against temperature and stress influence
- Customer-selectable PWM or SENT output
- 0.2 kHz to 2 kHz PWM (up to 12 bit)
- Push-pull or open-drain output
- SENT according to SAEJ2716 rev. 4
- Programmable arbitrary output characteristic with up to 33 setpoints
- Programming via the sensor's output pin
- Programmable first-order low-pass filter, as well as non-linear DNC filter
- Second-order temperature-dependent offset of signal path programmable for X- or Z-channel
- 32-bit identification number with TDK-Micronas production information (like X,Y position on the wafer, etc.)
- On-board diagnostics of different functional blocks of the sensor

2. Ordering Information

A Micronas device is available in a variety of delivery forms. They are distinguished by a specific ordering code:

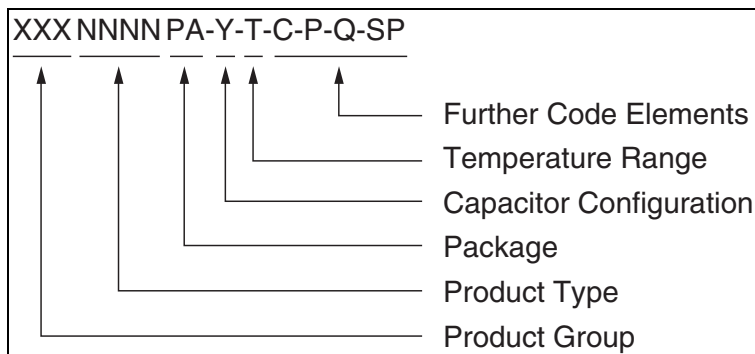

Fig. 2–1: Ordering code principle

For a detailed information, please refer to the brochure: “Sensors and Controllers: Ordering Codes, Packaging, Handling”.

2.1. Device-Specific Ordering Codes

The HAR 379x is available in the following package, capacitor, and temperature variants.

Table 2–1: Available packages

Package Code (PA)	Package Type
DJ	SOIC8-1

Table 2–2: Available temperature ranges

Temperature Code (T)	Temperature Range
A	$T_J = -40\text{ °C to }170\text{ °C}$

The relationship between ambient temperature (T_A) and junction temperature (T_J) is explained in Section 5.1. on page 47.

For available variants for Configuration (C), Packaging (P), Quantity (Q), and Special Procedure (SP) please contact TDK-Micronas.

Table 2–3: Available ordering codes and corresponding package marking

Available Ordering Codes	Package Marking
HAR3795DJ-A-[C-P-Q-SP]	3795A
HAR3796DJ-A-[C-P-Q-SP]	3796A
HAR3797DJ-A-[C-P-Q-SP]	3797A

3. Functional Description

3.1. General Function

HAR 379x is a 2D position sensor based on TDK-Micronas' 3D HAL technology. It is a dual-die integrated circuit with fully redundant signals. Each sensor includes two vertical and one horizontal Hall plate with spinning current offset compensation for the detection of X, Y or Z magnetic field components, a signal processor for calculation and signal conditioning of two magnetic field components, protection devices, and PWM or SAEJ2716 SENT output.

The spinning-current offset compensation minimizes the errors due to supply voltage and temperature variations as well as external package stress.

The signal path of HAR 379x consists of two channels (CH1 and CH2). Depending on the product variant two out of the three magnetic field components are assigned to channel 1 and channel 2.

The sensor can be used for angle measurements in a range between 0° and 360° (end-of-shaft and through-shaft setup) as well as for robust position detection (linear movement or position). The in-system calibration can be utilized by the system designer to optimize performance for a specific system. The calibration information is stored in an on-chip EEPROM.

The HAR 379x is programmable by modulation of the output voltage. No additional programming pin is needed.

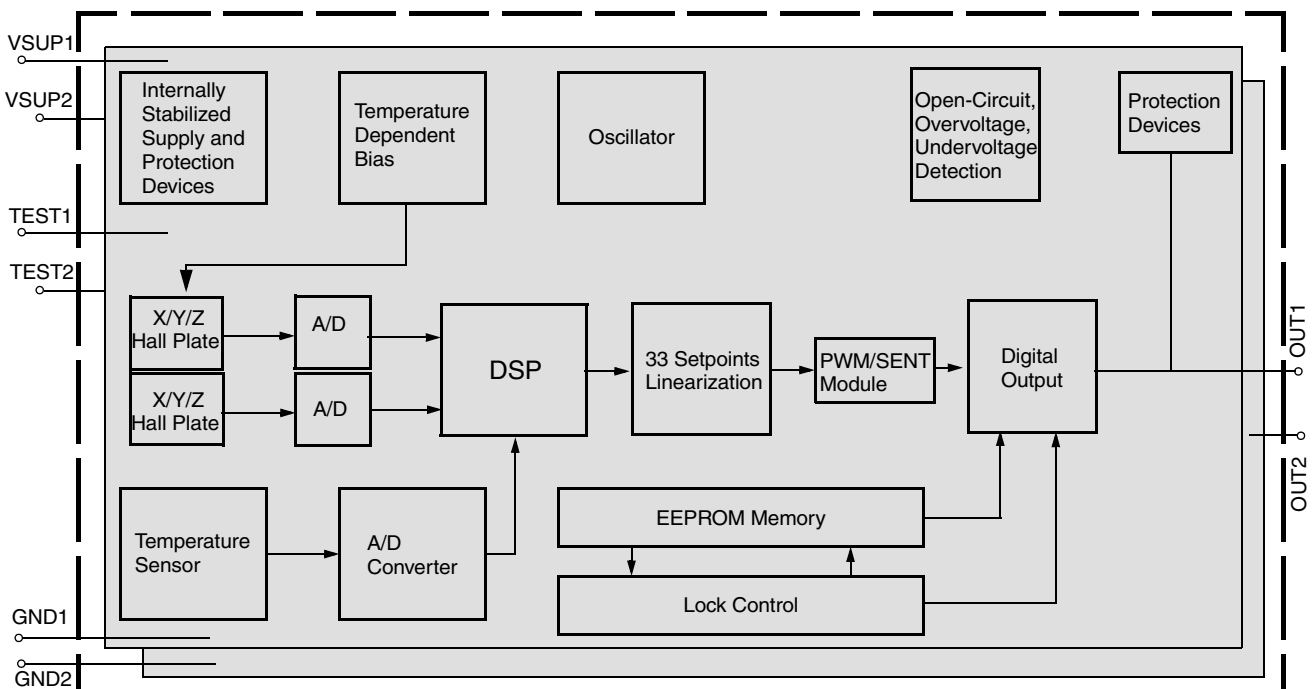

Fig. 3–1: HAR 379x block diagram

3.2. Signal Path

The DSP part of this sensor performs the signal conditioning. The parameters for the DSP are stored in the memory registers. Details of the signal path are shown in Fig. 3.2.

Terminology:

GAIN: name of the register or register value

Gain: name of the parameter

Blue color: register names

The sensor signal path contains two kinds of registers. Registers that are readout only (RAM) and programmable registers (EEPROM). The RAM registers contain measurement data at certain steps of the signal path and the EEPROM registers have influence on the sensors signal processing.

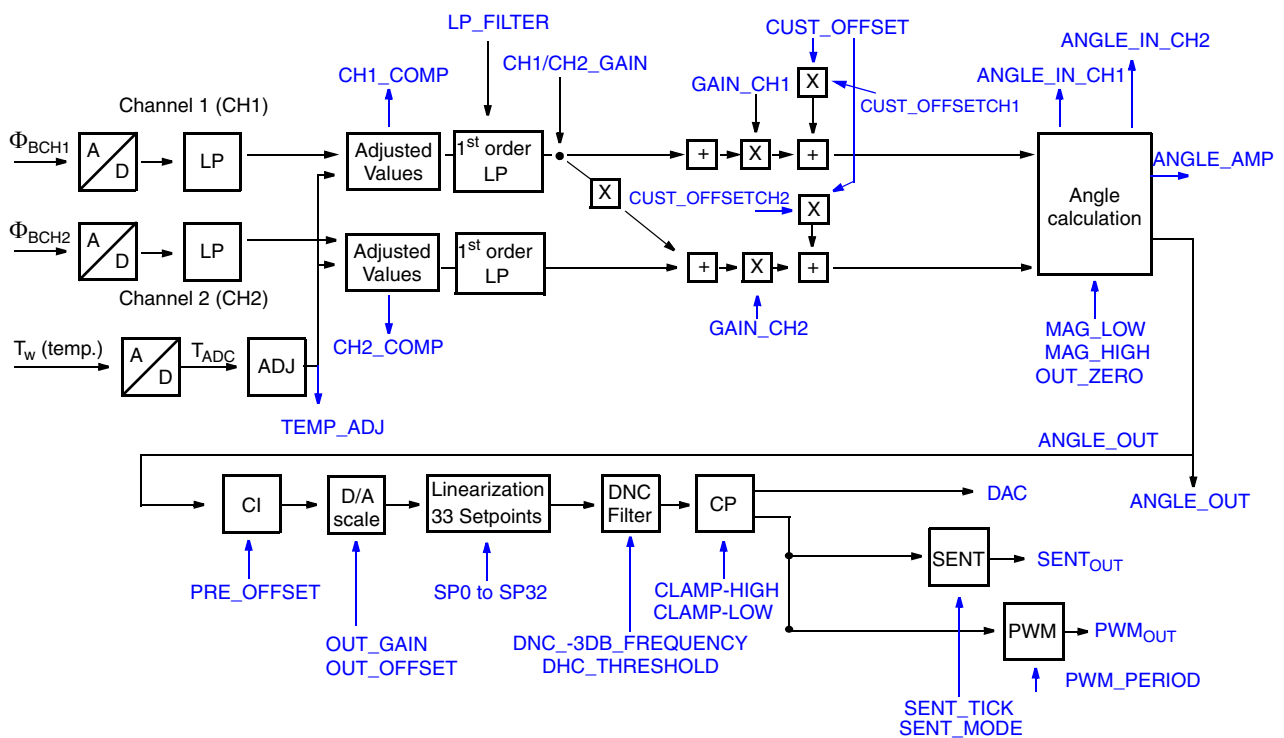

Fig. 3-2: Signal path of HAR 379x (equal for both dies)

3.3. Register Definition

3.3.1. RAM Registers

TEMP_ADJ

The TEMP_ADJ register contains the digital value of the sensor junction temperature. It has a length of 16 bit and is binary coded. From the 16 bit only the range between 0 ... 32767 is used for the temperature information. Typically the temperature sensor is calibrated in the way that at -40 °C the register value is 100 LSB and at 160 °C it is 12000 LSB.

CH1_COMP and CH2_COMP

CH1_COMP and CH2_COMP register contain the temperature compensated magnetic field information of channel 1 and channel 2. Both registers have a length of 16 bit each and are two's-complement coded. Therefore, the register values can vary between $-32768 \dots 32767$.

ANGLE_IN_CH1 and ANGLE_IN_CH2

ANGLE_IN_CH1 and ANGLE_IN_CH2 register contain the customer compensated magnetic field information of channel 1 and channel 2 used for the angle calculation. These registers include already customer phase-shift, gain and offset correction. Both registers have a length of 16 bit each and are two's-complement coded. Therefore, the register values can vary between $-32768 \dots 32767$.

ANGLE_OUT

The ANGLE_OUT register contains the digital value of the position calculated by the angle calculation algorithm. It has a length of 16 bit and is binary. From the 16 bit only the range between 0 ... 32767 is used for the position information. Position can either be an angular position (angle) or a virtual angle calculated out of two magnetic field directions in case of linear position measurements.

DAC

The DAC register contains the digital equivalent of the PWM output duty-cycle or the SENT data. It has a length of 16 bit and is binary. From the 16 bit only the range between 0 ... 32767 is used for the position information. Position can either be an angular position (angle) or a virtual angle calculated out of two magnetic field directions in case of linear position measurements.

ANGLE_AMP

The ANGLE_AMP register contains the digital value of the magnetic field amplitude calculated by the angle calculation algorithm. The device features two different algorithms for the amplitude calculation. The selection of the calculation depends on the content of the CUST_OFFSETCH1 and CUST_OFFSETCH2 registers. In case that both registers have the value zero (zero = customer offset switched off) the calculation is done by the following equation:

$$\text{ANGLE_AMP} \cong 1.6 \times \sqrt{\text{ANGLE_IN_CH1}^2 + \text{ANGLE_IN_CH2}^2}$$

The amplitude is calculated from the signals in channel 1 and channel 2 (X-/Y-/Z-components). The angle calculation algorithm adds a factor of roughly 1.6 to the equation for the magnetic amplitude.

In case that the customer offset is activated (CUST_OFFSETCH1 or CUST_OFFSETCH2 equal to 32767) the amplitude is calculated by the following equation:

$$\text{ANGLE_AMP} = |\text{ANGLE_IN_CH1}| + |\text{ANGLE_IN_CH2}|$$

DIAGNOSIS

The DIAGNOSIS register identifies certain failures detected by the sensor. HAR 379x performs self-tests during power-up as well as system integrity tests during normal operation. The result of those tests is reported via the DIAGNOSIS register. DIAGNOSIS register is a 16 bit register.

Table 3–1: DIAGNOSIS register

Bit No.	Function	Description
15:13	None	(must be zero)
12	Internal Supply Voltage Monitor	This bit is set to 1 in case that the internal stabilized voltage is too low.
11	ADC Stuck Error	This bit is set to 1 in case that one of the two A/D converters' signals is stuck at a fixed value.
10	None	(must be zero)
9	DAC Output High Clamping	This bit is set to 1 in case that the high clamping value of the DAC is reached.
8	DAC Output Low Clamping	This bit is set to 1 in case that the low clamping value of the DAC is reached.
7	Channel 1 Clipping	These bits are set to 1 in case that the A/D converter in channel 1 and/or 2 detects an under- or overflow.
6	Channel 2 Clipping	
5	DSP Self Test	The DSP is doing the internal signal processing like angle calculation, temperature compensation, etc. This bit is set to 1 in case that the DSP self test fails. (Continuously running)
4	EEPROM Self Test	This bit is set to 1 in case that the EEPROM self test fails. (Continuously running)
3	ROM Check	This bit is set to 1 in case that ROM parity check fails. (Continuously running)
2	Temperature Sensor Error	This bit is set to 1 in case that the temperature sensor does not deliver valid temperature information.
1	MAGHI	This bit is set to 1 in case that the magnetic field is exceeding the MAG-HIGH register value (magnetic field too high).
0	MAGLO	This bit is set to 1 in case that the magnetic field is below the MAG-LOW register value (magnetic field too low).

Details on the sensor self tests can be found in Section 3.5. on page 24.

PROG_DIAGNOSIS

The PROG_DIAGNOSIS register allows the customer to identify errors occurring during programming and writing of the EEPROM. The customer must check the first and second acknowledge. To enable debugging of the production line it is recommended to read back the PROG_DIAGNOSIS register in case of a missing second acknowledge. Please check the Programming Guide for HAR 379x for further details.

The PROG_DIAGNOSIS register is a 16 bit register. The following table shows the different bits indicating certain error possibilities.

Table 3–2: PROG_DIAGNOSIS register

Bit No.	Function	Description
15:11	None	(must be zero)
10	Charge Pump Error	This bit is set to 1 in case that the internal programming voltage was too low.
9	Voltage Error during Program/Erase	This bit is set to 1 in case that the internal supply voltage was too low during program or erase.
8:0	None	(must be zero)

3.3.2. EEPROM Registers

Note For production and qualification tests it is mandatory to set the LOCK bit after final adjustment and programming of HAR 379x. After locking the device it is still possible to read all memory content.

TDK-Micronas IDs

The MIC_ID1 and MIC_ID2 registers are both 16 bit organized. They are read only and contain TDK-Micronas production information, like X,Y position on the wafer, wafer number, etc.

Customer IDs

The CUST_ID1 and CUST_ID2 registers are both 16 bit organized. These two registers can be used to store customer production information, like serial number, project information, etc.

Low-Pass Filter

With the LP_FILTER register it is possible to select different -3 dB frequencies for HAR 379x. The Low-Pass Filter is a first-order digital filter and the register is 16 bit organized. Various typical filter frequencies between 4 kHz (no filter) and 10 Hz are available.

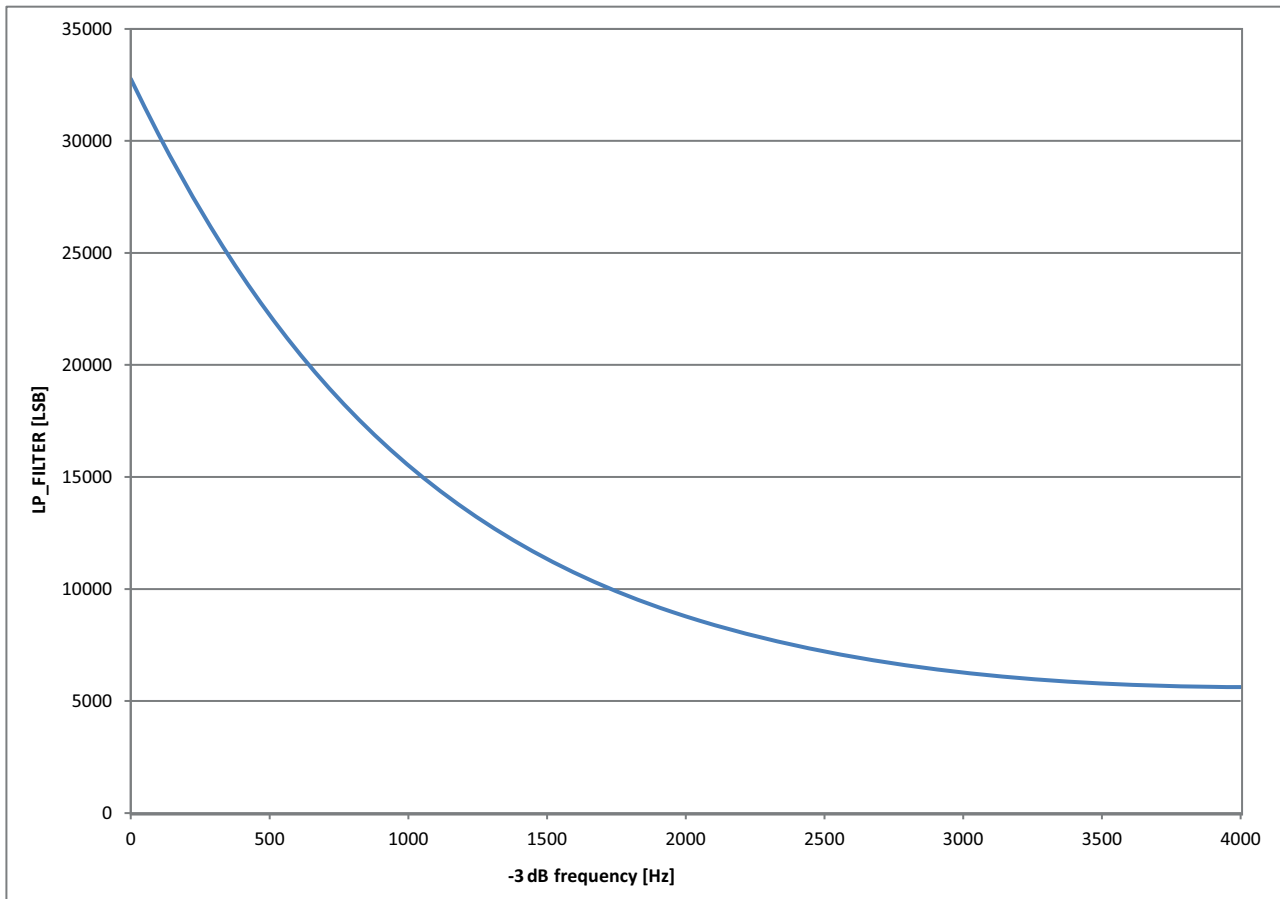

Fig. 3-3: -3dB filter frequency vs. LP_FILTER codes

CH1/CH2_GAIN

CH1/CH2_GAIN can be used to compensate a phase-shift between channel 1 and channel 2. The register has a length of 16 bit. It is possible to make a phase shift correction of $\pm 75^\circ$. The step size and therefore the smallest possible correction is 0.002° . The register is two's-complement coded and ranges from -32768 to 32767 . The register value is sin function based.

Neutral value for this register is zero (no phase-shift correction).

Note In case the phase-shift correction is used, then it is necessary to adapt the settings of GAIN_CH2 too. For details see definition of GAIN_CH2.

Gain for Channel 1 and 2

GAIN_CH1 and GAIN_CH2 can be used to compensate amplitude mismatches between channel 1 and channel 2. TDK-Micronas delivers pre calibrated sensors with compensated gain mismatch between channel 1 and channel 2. Nevertheless it is possible that due to the magnetic circuit a mismatch between channel 1 and channel 2 gain occurs. This can be compensated with GAIN_CH1 and GAIN_CH2.

Both registers have a length of 16 bit and are two's-complement coded. Therefore, they can have values between -32768 and 32767 ($-2 \dots 2$). For neutral settings both register values have to be set to 1 (register value 16384).

In case that the phase-shift correction is used it is necessary to change also the gain of channel 2 (see also CH1/CH2_GAIN). If phase-shift correction is used the corresponding register has to be set to

$$\text{GAIN_CH2} = \frac{16384}{\cos(\text{Phase-shift})}$$

Note In case GAIN_CH1 or GAIN_CH2 exceed the range of $-2 \dots 2$ ($-32768 \dots 32767$), then it is possible to reduce the gain of the opposite channel for compensation.

Customer Offset

CUST_OFFSET can be used to compensate an offset in channel 1 and channel 2. TDK-Micronas delivers pre calibrated sensors. Nevertheless it is possible that due to the magnetic circuit an offset in channel 1 and channel 2 occurs. This can be compensated with CUST_OFFSET.

The customer offset can also have a temperature coefficient to follow the temperature coefficient of a magnet. The customer offset consists of a polynomial of second-order represented by the three registers CUST_OFFSET1...3.

The customer offset can be added to channel 1 and/or channel 2 by the selection coefficients CUST_OFFSETCH1 and CUST_OFFSETCH2. Additionally, these two registers can be used to scale the temperature dependent offset between 0% and 100%

All five registers have a length of 16 bit and are two's-complement coded. Therefore, they can have values between -32768 and 32767 .

Output Signal Zero Position

OUT_Zero defines the reference position for the angle output. It can be set to any value of the output range. It is the starting point/reference for the 33 setpoints. OUT_ZERO has a register length of 16 bit and it is two's-complement coded.

Note Before reading ANGLE_OUT it is necessary to set OUT_ZERO to 0.

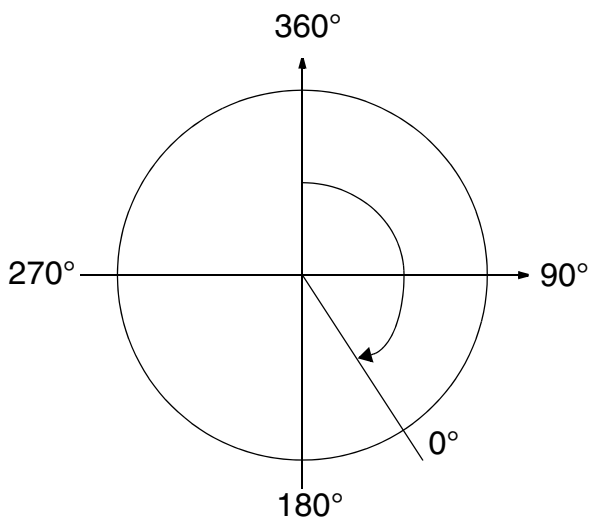

Fig. 3–4: Example definition of zero degree point

Secondly this angle can be used to shift the PI discontinuity point of the angle calculation to the maximum distance from the required angular range in order to avoid the 360°-wrapping of the output due to noise.

Magnetic Range Check

The magnetic range check uses the magnitude output and compares it with an upper and lower limit threshold defined by the registers MAG-LOW and MAG-HIGH. If either low or high limit is exceeded then the sensor will indicate it with an overflow on the sensors output (output high clamping).

Mag-Low Limit

MAG-LOW defines the low level for the magnetic field range check function. This register has a length of 16 bit and is two's complement number.

Mag-High Limit

MAG-HIGH defines the high level for the magnetic field range check function. This register has a length of 16 bit and is two's complement number.

Pre Offset

The PRE_OFFSET register allows to shift the angular range/the calculated angles into a new angle region to avoid an overflow of the D/A converter output signal.

The PRE_OFFSET register has a length of 16 bit and is two's complement coded.

Output Gain

OUT_GAIN defines the gain of the output signal. The register has a length of 16 bit and is two's-complement coded. OUT_GAIN = 1 is neutral setting and leads to a change of the output signal from 0% to 100% for an angle change from 0° to 360° (if OUT_OFFSET is set to 0).

OUT_GAIN can be changed between -64 and 64.

Output Offset

OUT_OFFSET defines the offset of the output signal. The register has a length of 16 bit and is two's complement coded. OUT_OFFSET = 0 is neutral setting and leads to a change of the output signal from 0% to 200% of V_{SUP} for an angle change from 0° to 360° (If OUT_GAIN is set to 1).

OUT_OFFSET can be changed between -200% and 200% of V_{SUP} . OUT_OFFSET = 0 leads to a voltage offset of 0% of V_{SUP} and OUT_OFFSET = -32768 leads to an offset of -200% of V_{SUP} .

Clamping Levels (CLAMP-LOW & CLAMP-HIGH)

The clamping levels CLAMP_LOW and CLAMP_HIGH define the maximum and minimum output voltage of the output signal. The clamping levels can be used to define the diagnosis band for the sensor output. Both registers have a bit length of 16 bit and are two's-complemented coded. Both clamping levels can have values between 0% and 100% of V_{SUP} .

DNC filter registers (DNC_-3DB_FREQUENCY & DNC_THRESHOLD)

The DNC (Dynamic Noise Cancellation) filter is a non-linear filter and can be used for further noise reduction in addition to the first order low-pass filter after the A/D converter. It decreases the output noise significantly by adding a low pass filter with a very low cut-off frequency for signals below a certain signal change threshold (DNC_THRESHOLD).

The amplification factor of this IIR filter can be selected by the register DNC_-3DB_FREQUENCY. The threshold can be selected by the register DNC_THRESHOLD. Both registers have a length of 16 bit and are two's complement coded. For DNC_THRESHOLD only values between -1 and -32768 are allowed. To disable the DNC filter DNC_THRESHOLD must be set to 0. For DNC_-3DB_FREQUENCY only positive values between 1 and 32767 are allowed. Recommended is a value of 2048.

Fig. 3-5 is showing the frequency response of the filter (as long as the signal change does not cross the selected DNC_THRESHOLD value) at some recommended filter settings.

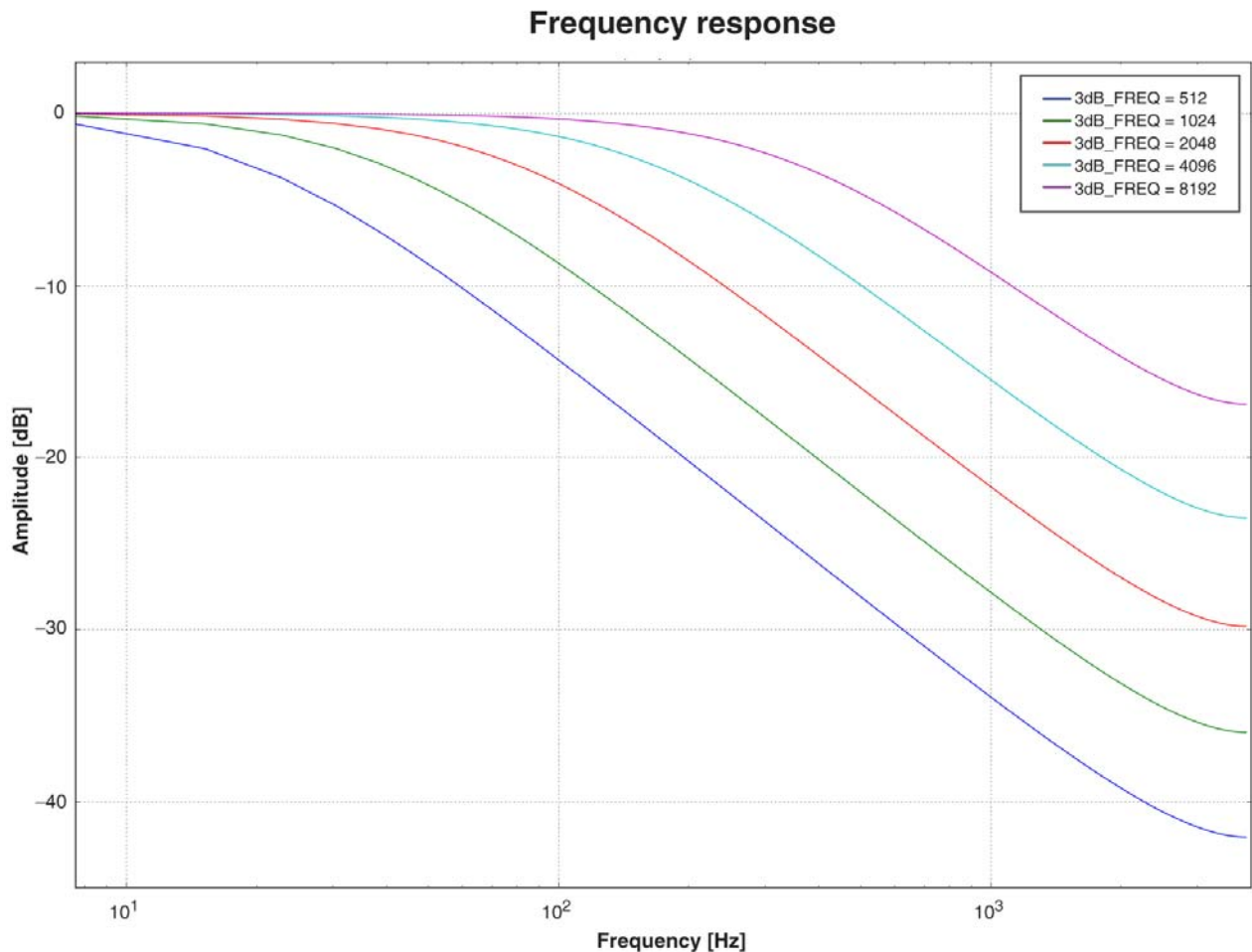

Fig. 3-5: DNC filter low-pass characteristic

Customer Setup Registers (CUST_SETUP1 & 2)

CUST_SETUP1 and CUST_SETUP2 registers are 16 bit registers that enable the customer to activate various functions of the sensor. CUST_SETUP1 is used to select functions like diagnosis modes, functionality mode, customer lock, etc. CUST_SETUP2 can be used to configure the PWM or SENT output.

Table 3–3: Customer Setup Register 1

Bit No.	Function	Description
14:15	Reserved	Must be set to zero.
13	SENT Channel 2	Defines if the device transmits temperature or magnetic field strength information in fast channel 2 in case of H.1 format. 0: Transmission of temperature information 1: Transmission of magnetic field amplitude
12	Digital Mode	0: PWM output 1: SENT output
11:8	Reserved	Must be set to zero.
7	Error Band	0: OUT = SENT (error code 4091) / PWM (freq. = 50% and duty cycle = 75%) in case of overvoltage 1: OUT = GND in case of overvoltage
6	Burn-In Mode	0: Disabled 1: Enabled
5	Functionality Mode	0: Extended 1: Normal (see Section 4.9. on page 41)
4	SENT Start-Up	Defines if the device transmits during start-up in SENT mode zero samples or 4094 until first valid sample available. 0: Transmission of 4094. Always no transmission of error bits in status nibble 1: Transmission of zero samples
3	Overvoltage Detection	0: Overvoltage detection active 1: Overvoltage detection disabled
2	Diagnosis Latch	Latching of diagnosis bits. 0: No latching 1: Latched till next POR (power-on reset)
1	Diagnosis	0: Show diagnostic errors on the output 1: Do not show diagnostic errors on the output
0	Customer Lock	Bit must be set to 1 to lock the sensor memory.

Table 3–4: Customer Setup Register 2

Bit No.	Function	Description																		
15	None	Must be set to zero																		
14:13	SENT sensor type	Defines the sensor type transmitted via slow channel. 00: Not specified 01: Linear position sensor 10: Angle position sensor 11: Relative position sensor																		
12	SENT data frame format	This bit together with bit 3 defines the different selectable data frame formats. 0: H.4 format - Secure single sensors (3 data nibble position information and 3 data nibble secure information) 1: H.1 format - 6 nibble. 12-bit position information and 12 bit temperature information/Magnetic Amplitude (see Table 3–3 Bit 13)																		
11:8	SENT tick time	Can be set between 0.5 μ s and 4.25 μ s in 0.25 μ s steps. 0000: 0.5 μ s 1111: 4.25 μ s																		
7	Output stage	0: Push-Pull output 1: Open-Drain output (Wire break detection circuit is still active)																		
6:4	SENT Mode selection	000: Pause Pulse active 101: No Pause Pulse																		
3	PWM polarity/SENT Frame content	This bit defines in case of PWM output mode the polarity of the PWM signal or in SENT output mode number of data nibbles (6 or 3 nibbles). New PWM Period starts with 0: Falling edge 1: Rising edge Number of SENT data nibbles 0: 3 data nibble 12-bit position information 1: 6 data nibble (see bit 12)																		
2:0	PWM_PERIOD or SENT frequency	These three bits are used to configure the PWM frequency or SENT message frame rate in case of operation with pause pulse. <table border="0"> <thead> <tr> <th>PWM</th> <th>SENT (SENTF)</th> </tr> </thead> <tbody> <tr> <td>000: 2.0 kHz (11 bit)</td> <td>8 kHz</td> </tr> <tr> <td>001: 1.6 kHz (11 bit)</td> <td>4 kHz</td> </tr> <tr> <td>010: 1.0 kHz</td> <td>2.66 kHz</td> </tr> <tr> <td>011: 800 Hz</td> <td>2 kHz</td> </tr> <tr> <td>100: 500 Hz</td> <td>1.6 kHz</td> </tr> <tr> <td>101: 400 Hz</td> <td>1 kHz</td> </tr> <tr> <td>110: 250 Hz</td> <td>0.8 kHz</td> </tr> <tr> <td>111: 200 Hz</td> <td>0.5 kHz</td> </tr> </tbody> </table>	PWM	SENT (SENTF)	000: 2.0 kHz (11 bit)	8 kHz	001: 1.6 kHz (11 bit)	4 kHz	010: 1.0 kHz	2.66 kHz	011: 800 Hz	2 kHz	100: 500 Hz	1.6 kHz	101: 400 Hz	1 kHz	110: 250 Hz	0.8 kHz	111: 200 Hz	0.5 kHz
PWM	SENT (SENTF)																			
000: 2.0 kHz (11 bit)	8 kHz																			
001: 1.6 kHz (11 bit)	4 kHz																			
010: 1.0 kHz	2.66 kHz																			
011: 800 Hz	2 kHz																			
100: 500 Hz	1.6 kHz																			
101: 400 Hz	1 kHz																			
110: 250 Hz	0.8 kHz																			
111: 200 Hz	0.5 kHz																			

3.4. Output Linearization

In certain applications (e.g. through shaft applications or position measurements) it is required to linearize the output characteristic. The resulting output characteristic “value vs. angle/position” is not a linear curve as in the ideal case. But it can be linearized by applying an inverse nonlinear compensation curve.

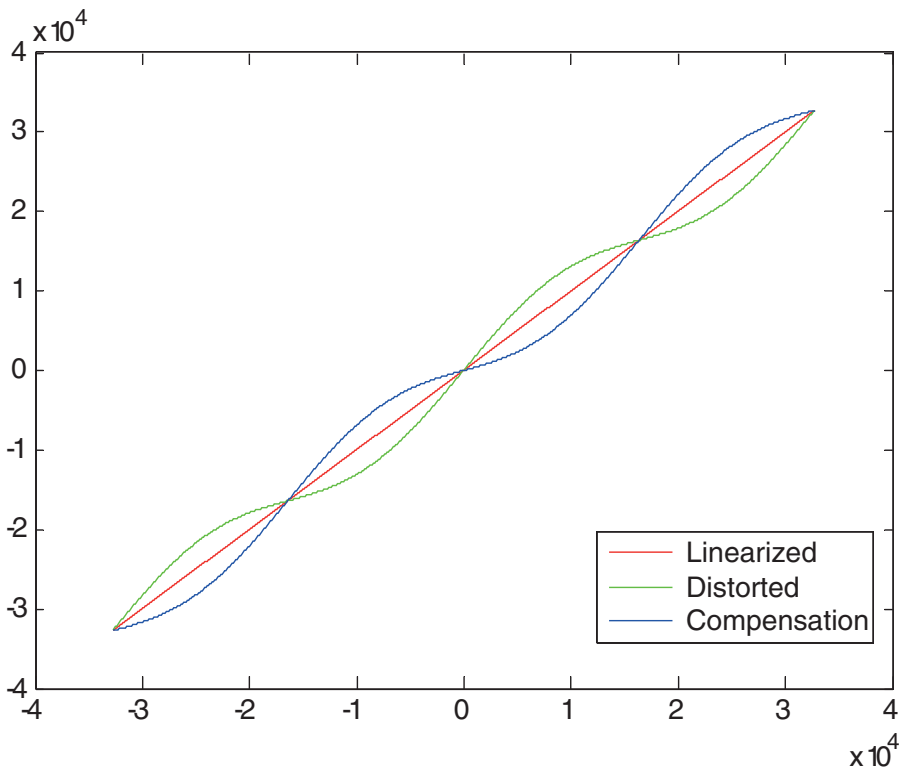

Fig. 3–6: Example for output linearization

For this purpose the compensation curve will be divided into 33 segments with equal distance. Each segment is defined by two setpoints, which are stored in EEPROM. Within the interval, the output is calculated by linear interpolation according to the position within the interval.

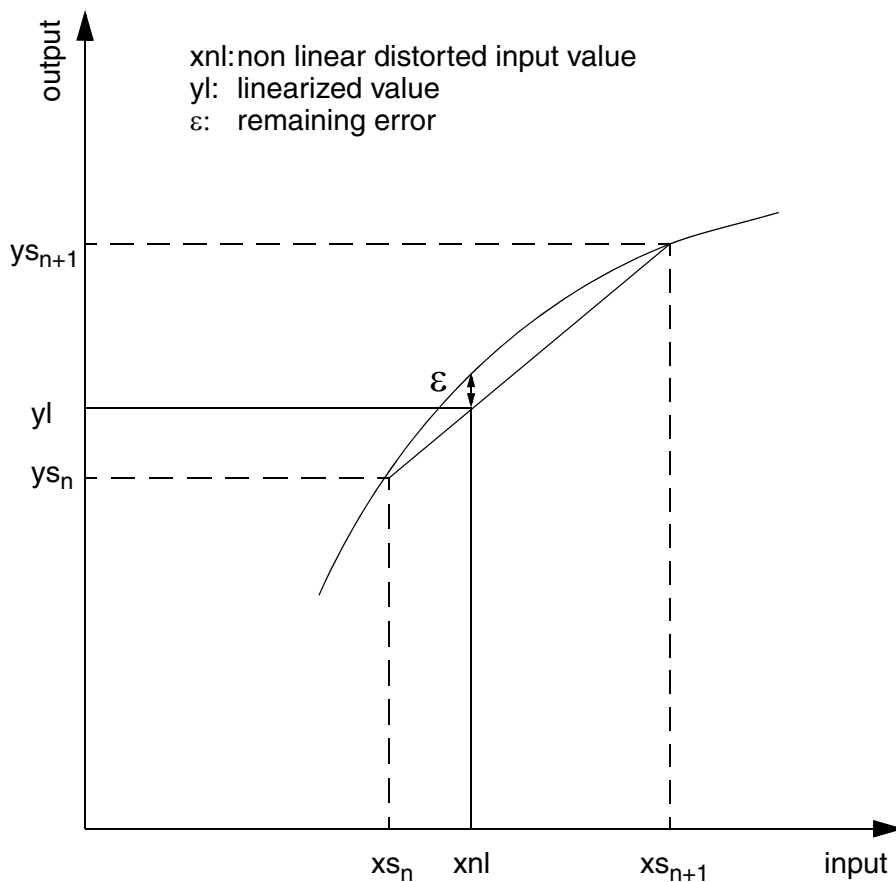

Fig. 3–7: Linearization - detail

The constraint of the linearization is that the input characteristic has to be a monotonic function. In addition, it is recommended that the input does not have a saddle point or inflection point, i.e. regions where the input is nearly constant. This would require a high density of set points.

To do a linearization the following steps are necessary:

- Measure output characteristics over full range
- Find the inverse (Point-wise mirroring the graph on the bisectrix)
- Do a spline fit on the inverse
- Insert digital value of set point position into spline fit function for each set point (0, 1024, 2048, ..., 32767)
- Resulting values can be directly entered into the EEPROM

3.5. On-Board Diagnostic Features

The HAR 379x features two groups of diagnostic functions. The first group contains basic functions that are always active. The second group can be activated by the customer and contains supervision and self-tests related to the signal path and sensor memory.

Diagnostic features that are always active:

- Wire-break detection for supply and ground line
- Undervoltage detection
- Thermal supervision of output stage (overcurrent, short circuit, etc.)

Diagnostic features that can be activated by customer:

- Continuous internal supply voltage monitoring
- A/D converter stuck error
- Output signal clamping
- A/D converter clipping
- Continuous state machine self-test
- Continuous EEPROM self-test (only if bit 2 in CUST_SETUP1 = 1)
- Continuous ROM parity check
- Temperature sensor error
- Magnetic range detection
- Overvoltage detection

HAR 379x indicates a failure by changing the PWM frequency. The different errors are then coded in different duty-cycles.

Table 3–5: Failure indication for HAR 379x in PWM mode

Failure Mode	Frequency	Duty-Cycle
EEPROM, ROM, A/D converter stuck error, state machine self-test and the internal supply voltage monitor	50%	95%
Magnetic field too low	50%	62.5%
Magnetic field too high	50%	55%
V _{SUP} Overvoltage (CUST_SETUP1, bit 7 = 0)	50%	75%
V _{SUP} Overvoltage (CUST_SETUP1, bit 7 = 1)	Output driven to low output state	
Temperature error	50%	85%
Undervoltage	No PWM	n.a.
A/D converter clipping	50%	70%

In case of undervoltage, the sensors will go into reset and the output will be actively driven to low output state.

Note

In case of an error the sensors change the selected PWM frequency.

Example: During normal operation the PWM frequency is 1 kHz, in case of an error 500 Hz.

HAR 379x is transmitting detailed error codes in case of selected SENT output. Further details can be found in Section 3.6. on page 26.

3.6. SENT Output Protocol

HAR 379x complies with the SAEJ2716 standard rev. 4 and supports the following three frame formats:

- Two 12-bit Fast Channels (3 nibble position information and 3 nibble temperature information or magnetic field amplitude)
- One 12-bit Fast Channel (3 nibble position information)
- Secure Single Sensors with 12-bit Fast Channel (3 nibble position information) and 12-bit Secure Sensor Information

All different modes are customer selectable via EEPROM bits (see Table 3–4 on page 21).

In SENT output mode the unidirectional communication from the sensor to a receiver module (e.g. an Electronic Control Unit) occurs independently of any action of the receiver module. It does not require any synchronization signal from the receiver module and does not include a coordination signal from the controller/receiving devices.

3.6.1. 6 Data Nibble Frame with Two Fast Channels (H.1 Format SAEJ2716 rev. 4)

In this SENT mode the sensor transmits SENT frames with 6 data nibbles. 3 data nibbles with 12-bit position information and 3 data nibbles with 12-bit temperature information or 12-bit magnetic field amplitude information (customer configurable). They are formatted according to Table 3–6.

Table 3–6: Nibble description for 6 data nibble frame format with two fast channels

Pulse		Remarks
#	Description	
1	Synchronization/Calibration	It is mandatory to measure the synchronization / calibration period for calibration of the clock tick time t_{tick} at the ECU
2	4-bit Status & Communication Nibble	Status [0]: 1, if CUST_SETUP1-bit 4 = 1 & error; otherwise 0 Status [1]: 1, if CUST_SETUP1-bit 4 = 1 & temp. error; otherwise 0 Status [3:2]: Enhanced Serial Message (see Section 3.6.8. on page 30)
3	4-bit Data Nibble MSN 1	Position Value [11:8]
4	4-bit Data Nibble MidN 1	Position Value [7:4]
5	4-bit Data Nibble LSN 1	Position Value [3:0]
6	4-bit Data Nibble LSN 2	Chip Temperature Value [3:0] or Magnetic Amplitude Value [3:0]
7	4-bit Data Nibble MidN 2	Chip Temperature Value [7:4] or Magnetic Amplitude Value [7:4]
8	4-bit Data Nibble MSN 2	Chip Temperature Value [11:8] or Magnetic Amplitude Value [11:8]
9	4-bit CRC Nibble	Enhanced CRC see SAEJ2716
10	Pause Pulse	Optional. Customer configurable.

3.6.2. 3 Data Nibble Frame with One Fast Channel (H.2 Format SAEJ2716 rev. 4)

In this SENT mode the sensor transmits SENT frames with 3 data nibbles containing 12-bit position information. They are formatted according to Table 3–7.

Table 3–7: Nibble description for 3 data nibble frame format with one fast channel

Pulse		Remarks
#	Description	
1	Synchronization/ Calibration	It is mandatory to measure the synchronization / calibration period for calibration of the clock tick time t_{tick} at the ECU
2	4-bit Status & Communication Nibble	Status [0]: 1, if CUST_SETUP1-bit 4 = 1 & error; otherwise 0 Status [1]: 0 Status [3:2]: Enhanced Serial Message (see Section 3.6.8. on page 30)
3	4-bit Data Nibble MSN 1	Position Value [11:8]
4	4-bit Data Nibble MidN 1	Position Value [7:4]
5	4-bit Data Nibble LSN 1	Position Value [3:0]
6	4-bit CRC Nibble	Enhanced CRC see SAEJ2716
7	Pause Pulse	Optional. Customer configurable.

3.6.3. 6 Data Nibble Frame with Secure Information (H.4 Format SAEJ2716 rev. 4)

In this SENT mode the sensor transmits SENT frames with 3 data nibbles containing 12-bit position information as well as 3 data nibbles containing 12-bit secure sensor information. The secure sensor information consists of an 8 bit rolling counter and the inverted copy of the MSN of the transmitted position information. They are formatted according to Table 3–8.

Table 3–8: Nibble description for 6 data nibble frame format with secure information

Pulse		Remarks
#	Description	
1	Synchronization/ Calibration	It is mandatory to measure the synchronization / calibration period for calibration of the clock tick time t_{tick} at the ECU
2	4-bit Status & Communication Nibble	Status [0]: 1, if CUST_SETUP1-bit 4 = 1 & error; otherwise 0 Status [1]: 0 Status [2:3]: Enhanced Serial Message (see Section 3.6.8. on page 30)
3	4-bit Data Nibble MSN 1	Position Value [11:8]
4	4-bit Data Nibble MidN 1	Position Value [7:4]
5	4-bit Data Nibble LSN 1	Position Value [3:0]
6	4-bit Data Nibble MSN 2	Rolling Counter MSN
7	4-bit Data Nibble MidN 2	Rolling Counter LSN
8	4-bit Data Nibble LSN 2	Inverted Copy of Data Nibble MSN 1
9	4-bit CRC Nibble	Enhanced CRC see SAEJ2716
10	Pause Pulse	Optional. Customer configurable.

3.6.4. Error Diagnostic Reporting on Fast Channel

The Status bits are set to one in case of “sensor error indication” or “sensor functionality and processing error indication” as long as bit 4 in CUST_SETUP1 is set to one.

If bit 4 is set to zero Status bits are always zero.

In addition the diagnostic can be reported through the 12 bit payload of channel 1 and/or channel 2. Below table shows the values that will be send in case of an internal error.

Table 3–9: Error codes transmitted on fast channel 1 and/or 2

Error	Code	
	CH 1	CH 2
Sensor error indication	4091	N/A
Sensor functionality and processing error indication	4090	4090
Data Clamping: High	4088	4088
Data Clamping: Low	1	1

Note CH 2 is only showing error code 4090 in case of a temperature error. All other errors will be indicated on CH 1 only.

The transmission of error codes on fast channel 1 and/or 2 can be deactivated by a customer EEPROM bit (bit 1 of Customer Setup Register 1, Table 3–3 on page 20). The sensor will then continue to transmit measurement data, but Status Error will be still set to 1.

3.6.4.1. Impact of Diagnosis Bit (CUST_SETUP1 - bit 1) on SENT Output

The following table describes the impact of the Diagnosis bit on the error indication in SENT mode depending on the Pause Pulse configuration. Table 3–10 shows the behavior for the H.2 and H.4 format. Table 3–11 describes the behavior in case of the H.1 format.

Table 3–10: Error indication in H.2 and H.4 format

DIAGNOSIS bit	Effect on	Pause Pulse active	No Pause Pulse
0: Enabled	Status [0]	Shows diagnosis error	Shows diagnosis error and double data transmission
	Fast Channel 1	Shows diagnosis error code	Shows diagnosis error code
1: Disabled	Status [0]	Shows diagnosis error	Shows no diagnosis error but double data transmission information
	Fast Channel 1	Shows no diagnosis error code	Shows no diagnosis error code

Table 3–11: Error indication in H.1 format

DIAGNOSIS bit	Effect on	Pause Pulse active	No Pause Pulse
0: Enabled	Status [0]	Shows diagnosis error	Shows diagnosis error and double data transmission
	Fast Channel 1	Shows diagnosis error code	Shows diagnosis error code
	Status [1]	Shows diagnosis error	Shows diagnosis error
	Fast Channel 2	Shows diagnosis error code	Shows diagnosis error code
1: Disabled	Status [0]	Shows diagnosis error	Shows no diagnosis error but double data transmission information
	Fast Channel 1	Shows no diagnosis error code	Shows no diagnosis error code
	Status [1]	Shows diagnosis error	Shows diagnosis error
	Fast Channel 2	Shows no diagnosis error code	Shows no diagnosis error code

Note Table 3–10 and Table 3–11 are only valid if bit 4 of CUST_SETUP1 register is set to one.

3.6.5. Timing of Error Reporting on Fast Channel

In worst case it will take two SENT frames to indicate an error on the output. The overall time depends on the selected frame format and tick time.

3.6.6. Pause Pulse

The pause pulse is present at the end of every frame as defined by the SAEJ2716 standard. Alternatively the pause pulse can be deactivated by a bit combination in the configuration memory (see Table 3–4 on page 21). The length of the pause pulse is automatically adjusted by the chip internal SENT block in order to achieve a constant frame period independent from the message content. The length depends on the frame content and the selected SENT message frequency, as well as on the selected tick time (see Table 3–15 on page 34).

It is possible that in case of deactivated pause pulse some samples may be transmitted twice in series due to the fact that the message time can be shorter than the sample time. Status[0] bit will be set to one in case that a sample is transmitted twice.

Please refer to Table 3–17 and Table 3–18 on page 35 showing tick times allowing a sample synchronous transmission.

3.6.7. CRC Implementation

HAR 379x supports the new recommended CRC implementation defined in SAEJ2716 rev. 4. The old legacy CRC is not supported.

3.6.8. Slow Channel: Enhanced Serial Message

HAR 379x transmits the slow message according to the Enhanced Serial Message Format as specified in the SENT standard SAEJ2716 with the following setup:

The configuration bit is always 0, representing 12-bit data and 8-bit message ID.

3.6.9. Slow Channel: Serial Message Sequence

The device is always transmitting the serial message sequence shown in Table 3–12.

Table 3–12: Serial Message Sequence

#	8-bit ID	Item	12-bit Data	Comment
1	0x03	Sensor type	(see Table 3–14 on page 33)	Customer programmable
2	0x29	TDK-Micronas SN	8-bit MSB MIC_ID1	MSB TDK-Micronas Serial Number register 1. Right aligned
3	0x2A	TDK-Micronas SN	8-bit LSB MIC_ID1	LSB TDK-Micronas Serial Number register 1. Right aligned
4	0x01	Error Codes	(see Table 3–13 on page 32)	
5	0x2B	TDK-Micronas SN	8-bit MSB MIC_ID2	MSB TDK-Micronas Serial Number register 2. Right aligned
6	0x2C	TDK-Micronas SN	8-bit LSB MIC_ID2	LSB TDK-Micronas Serial Number register 2. Right aligned
7	0x05	Manufacturer Code	0x007	TDK-Micronas Manufacturer Code
8	0x01	Error Codes	(see Table 3–13 on page 32)	
9	0x06	Protocol revision	0x004	SAEJ2716 rev. 4
10	0x23	Temperature	1 ... 4088: Temperature Data 4090: Temperature Error	12-bit internal reference temperature. Transfer function TDK-Micronas specific.
11	0x1C	Field strength	1 ... 4088: Calculated magnetic field amplitude	Transfer characteristic is not transmitted
12	0x01	Error Codes	(see Table 3–13 on page 32)	

3.6.10. Slow Channel: Serial Message Error Codes

Diagnostic status codes are transmitted via the serial message. The 8-bit message ID for the diagnostic status code is 0x01. The 12-bit code within the 12-bit message can be defined by the device manufacturer in the range between 0x800 to 0xFFF. HAR 379x feature the error codes described in Table 3–13.

Table 3–13: Serial Message Error Codes

Bit Position	Error Type
0	Memory error
1	Signal path error
2	Voltage regulator error
3	Magnetic field amplitude out of range error
4	Temperature sensor value not valid
5	Signal path over/underflow error
6	Overvoltage error
7:10	Always 0
11	Always 1

Note Diagnostic latch bit (Customer Setup Register 1[2]) (see Table 3–3 on page 20) must be set to one to ensure stable transmission of error codes. Especially for momentary errors.

3.6.11. Slow Channel: Sensor Types

HAR 379x can transmit the sensor type information via the slow channel. The sensor type depends on the final customer application and is therefore customer programmable (Customer Setup Register 2, bit 14 and 13). Table 3–14 shows the transmitted 12-bit value depending on the selected frame format and sensor function.

Table 3–14: Selectable Sensor Types

Bit combination	12-bit Value	Description
00	0x050	Not specified
Format: 6 data nibble with two fast channels		
01	0x056	Linear position
10	0x065	Angle position
11	0x075	Relative position
Format: 3 data nibble with one fast channel		
01	0x051	Linear position
10	0x060	Angle position
11	0x070	Relative position
Format: 6 data nibble with secure information		
01	0x055	Linear position
10	0x064	Angle position
11	0x074	Relative position

3.6.12. Start-Up Behavior

The start-up behavior is customer configurable. The device can either transmit zero messages until a valid information is available (SAEJ2716 conform). Alternatively the device transmits 4094 until a valid information is available. The start-up behavior is customer configurable by bit 4 in the CUST_SETUP1 register.

3.6.13. Message Time for SENT Frames with Pause Pulse

The SENT frame repetition frequency (SENTF) is defined by the position sampling frequency. The selectable SENT frame repetition frequency is limited by the configured tick time, the transmitted data value and the minimum and maximum pause pulse duration.

The tick time is customer programmable and can be selected between 0.5 μs and 4.25 μs in steps of 0.25 μs . The tick time is defined by bits 11 to 8 in the Customer Setup Register 2 (see Table 3–4 on page 21).

The pulse low time is fixed to 5 ticks. The minimum pause pulse duration is 12 ticks.

The delivery of new position values is synchronous with the SENT messages, i.e. one SENT message is transmitted per position sample. Thus, the propagation delay is very low and the message time is nearly constant.

Table 3–15 and Table 3–16 show the recommended sample frequencies for certain tick times to ensure samples synchronous transmission.

Table 3–15: Recommended tick time settings for 6 data nibble transmission

t_{tick}^1 [μs]	0.50	0.75	1.00	1.25	1.50	1.75	2.00	2.25	2.50	2.75	3.00	3.25	3.50	3.75	4.00	4.25
TICK [LSB]	0	1	2	3	4	5	6	7	8	9	10	11	12	13	14	15
SENTF [Hz]																
4000	NC	NC	–	–	–	–	–	–	–	–	–	–	–	–	–	–
2660	NC	NC	NC	NC	–	–	–	–	–	–	–	–	–	–	–	–
2000	NC	NC	NC	NC	NC	NC	–	–	–	–	–	–	–	–	–	–
1600	NC	NC	NC	NC	NC	NC	NC	NC	–	–	–	–	–	–	–	–
1000	NC	NC	NC	NC	NC	NC	NC	NC	NC	SC	SC	SC	SC	–	–	–
800	NC	NC	NC	NC	NC	NC	NC	NC	NC	SC	SC	SC	SC	SC	SC	SC
500	NC	NC	NC	NC	NC	NC	NC	NC	NC	SC	SC	SC	SC	SC	SC	SC

¹⁾ Clock tolerance of $\pm 10\%$ is not included
 NC: None SAEJ2716 conform settings
 SC: SAEJ2716 specification conform settings

Table 3–16: Recommended tick time settings for 3 data nibble transmission

$t_{\text{tick}}^{1)}$ [μs]	0.50	0.75	1.00	1.25	1.50	1.75	2.00	2.25	2.50	2.75	3.00	3.25	3.50	3.75	4.00	4.25
TICK [LSB]	0	1	2	3	4	5	6	7	8	9	10	11	12	13	14	15
SENTF [Hz]																
8000	NC	–	–	–	–	–	–	–	–	–	–	–	–	–	–	–
4000	NC	NC	NC	NC	–	–	–	–	–	–	–	–	–	–	–	–
2660	NC	NC	NC	NC	NC	NC	–	–	–	–	–	–	–	–	–	–
2000	NC	NC	NC	NC	NC	NC	NC	NC	NC	–	–	–	–	–	–	–
1600	NC	NC	NC	NC	NC	NC	NC	NC	NC	SC	SC	–	–	–	–	–
1000	NC	NC	NC	NC	NC	NC	NC	NC	NC	SC	SC	SC	SC	SC	SC	SC
800	NC	NC	NC	NC	NC	NC	NC	NC	NC	SC	SC	SC	SC	SC	SC	SC
500	NC	NC	NC	NC	NC	NC	NC	NC	NC	SC	SC	SC	SC	SC	SC	SC

¹⁾ Clock tolerance of $\pm 10\%$ is not included
 NC: None SAEJ2716 conform settings
 SC: SAEJ2716 specification conform settings

Table 3–17 and Table 3–18 show allowed settings leading to sample synchronous transmission in case of deactivated pause pulse.

Table 3–17: Recommended tick time settings for 6 data nibble transmission for sample accurate transmission

$t_{\text{tick}}^{1)}$ [μs]	0.50	0.75	1.00	1.25	1.50	1.75	2.00	2.25	2.50	2.75	3.00	3.25	3.50	3.75	4.00	4.25
TICK [LSB]	0	1	2	3	4	5	6	7	8	9	10	11	12	13	14	15
	DT	DT	ST	ST	ST	ST	ST	ST	ST	ST	ST	ST	ST	ST	ST	ST

¹⁾ Clock tolerance of $\pm 10\%$ is not included
 DT: Double transmission of measurement values possible and indicated in Status[0]
 ST: Sample synchronous transmission of measurement values

Table 3–18: Recommended tick time settings for 3 data nibble transmission for sample accurate transmission

$t_{\text{tick}}^{1)}$ [μs]	0.50	0.75	1.00	1.25	1.50	1.75	2.00	2.25	2.50	2.75	3.00	3.25	3.50	3.75	4.00	4.25
TICK [LSB]	0	1	2	3	4	5	6	7	8	9	10	11	12	13	14	15
	DT	DT	DT	ST	ST	ST	ST	ST	ST	ST	ST	ST	ST	ST	ST	ST

¹⁾ Clock tolerance of $\pm 10\%$ is not included
 DT: Double transmission of measurement values possible and indicated in Status[0]
 ST: Sample synchronous transmission of measurement values

4. Specifications

4.1. Outline Dimensions

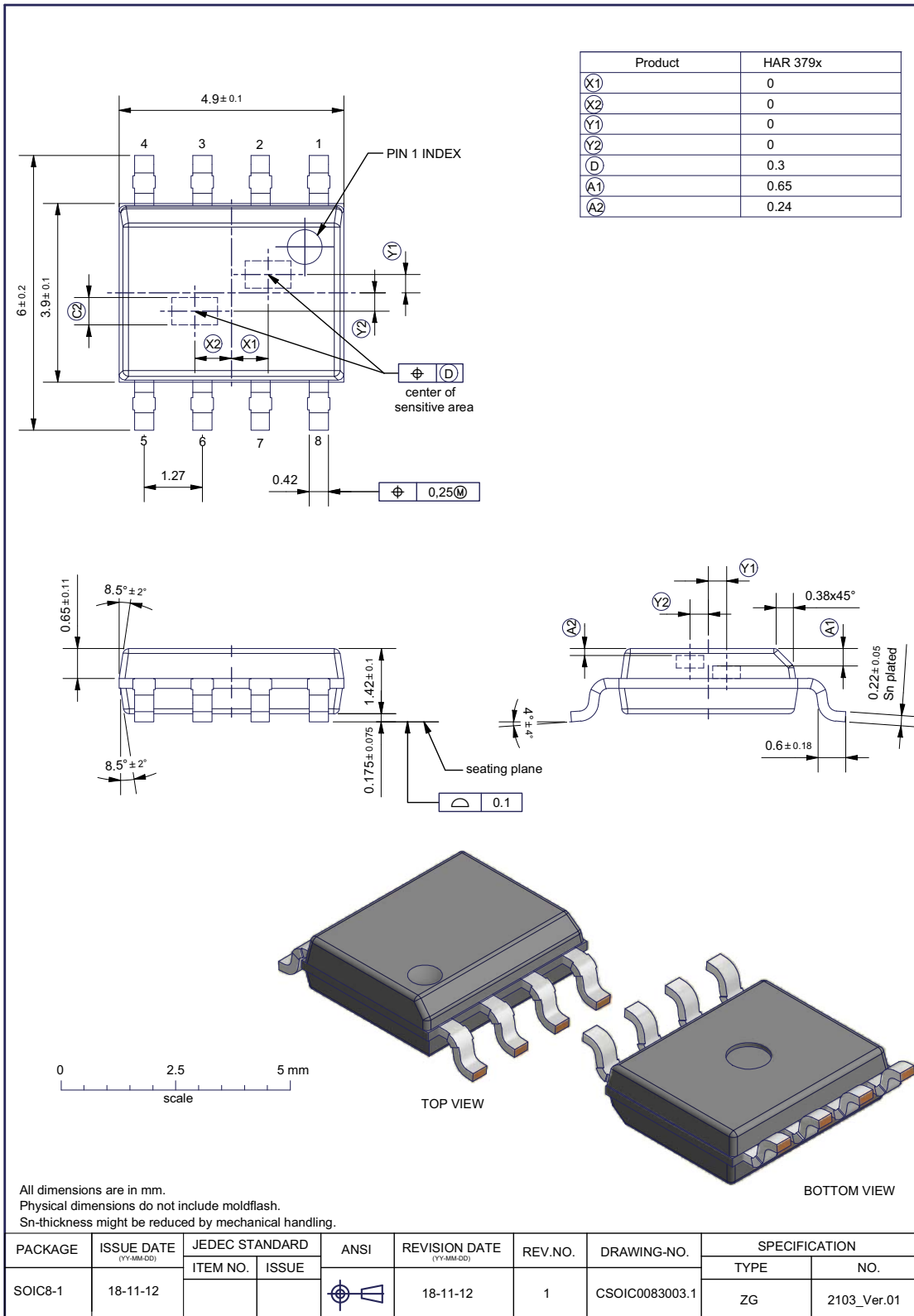

© Copyright 2018 TDK-Micronas GmbH, all rights reserved

Fig. 4-1:
SOIC8-1: Plastic Small Outline IC package, 8 leads, gullwing bent, 150 mil
 Ordering code: DJ
 Weight approximately 0.076 g

4.2. Soldering, Welding, Assembly

Information related to solderability, welding, assembly, and second-level packaging is included in the document “Guidelines for the Assembly of Micronas Packages”.

It is available on the TDK-Micronas website (<https://www.micronas.com/en/service-center/downloads>) or on the service portal (<https://service.micronas.com>).

4.3. Storage and Shelf Life Package

Information related to storage conditions of Micronas sensors is included in the document “Guidelines for the Assembly of Micronas Packages”. It gives recommendations linked to moisture sensitivity level and long-term storage.

It is available on the TDK-Micronas website (<https://www.micronas.com/en/service-center/downloads>) or on the service portal (<https://service.micronas.com>).

4.4. Size of Sensitive Area

Hall plate area = 275 μm x 275 μm .

See Fig. 4–1 on page 36 for more information on the Hall plate position.

4.5. Definition of Magnetic-Field Vectors

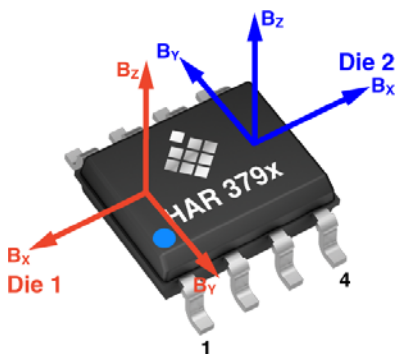

Note

Die 2 is 180° rotated in relation to die 1. Therefore the measurement values of X and Y components have opposite signs compared to die 1.

4.6. Pin Connections and Short Description

Pin No.	Pin Name	Type	Short Description
Die 1			
1	VSUP1	SUPPLY	Supply Voltage 1
2	GND1	GND	Ground 1
3	TEST1	I/O	Test 1
4	OUT1	I/O	Output and Programming Pin 1
Die 2			
5	VSUP2	SUPPLY	Supply Voltage 2
6	GND2	GND	Ground 2
7	TEST2	I/O	Test 2
8	OUT2	I/O	Output and Programming Pin 2

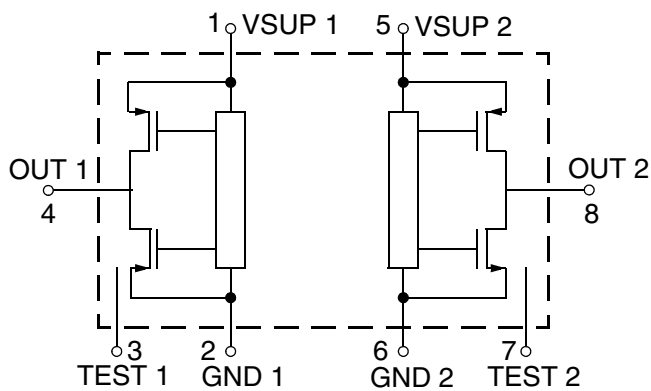

Fig. 4–2: Pin configuration

Note It is recommended to connect the TEST1 pin to GND1 and to connect the TEST2 pin to GND2.

4.7. Absolute Maximum Ratings

Stresses beyond those listed in the “Absolute Maximum Ratings” may cause permanent damage to the device. This is a stress rating only. Functional operation of the device at these conditions is not implied. Exposure to absolute maximum rating conditions for extended periods will affect device reliability.

This device contains circuitry to protect the inputs and outputs against damage due to high static voltages or electric fields; however, it is advised that normal precautions be taken to avoid application of any voltage higher than absolute maximum-rated voltages to this high-impedance circuit.

All voltages listed are referenced to ground (GND).

Symbol	Parameter	Pin Name	Min.	Max.	Unit	Condition
V_{SUP}	Supply Voltage	VSUPx	-20	20	V	$t < 1 \text{ hr}^2$)
V_{OUT}	Output Voltage	OUTx	-6	20	V	$t < 1 \text{ hr}^2$)
$V_{OUT} - V_{SUP}$	Excess of Output Voltage over Supply Voltage	OUTx, VSUPx	-	2	V	
I_{OUT}	Continuous Output Current	OUTx	-10	10	mA	
T_A	Ambient Temperature	-	-40	160	°C	³⁾
$T_{storage}$	Transportation/Short Term Storage Temperature	-	-55	150	°C	Device only without packing material
B_{max}	Magnetic Field	-	-	unlimited	T	
V_{ESD}	ESD Protection	VSUPx, GNDx, OUTx, TESTx	-2	2	kV	¹⁾ For all pin combinations (including die 1 to die 2)
		VSUP1, GND1, OUT1, TEST1	-4	4	kV	¹⁾ For all pin combinations (die 1 only)
		VSUP2, GND2, OUT2, TEST2	-4	4	kV	¹⁾ For all pin combinations (die 2 only)
¹⁾ AEC-Q100-002 (100 pF and 1.5 kΩ) ²⁾ No cumulated stress ³⁾ Consider current consumption, mounting condition (e.g. overmold, potting) and mounting situation for T_A in relation to T_J						

4.8. Recommended Operating Conditions

Functional operation of the device beyond those indicated in the “Recommended Operating Conditions/Characteristics” is not implied and may result in unpredictable behavior, reduced reliability and lifetime of the device.

All voltages listed are referenced to ground (GND).

Symbol	Parameter	Pin Name	Min.	Typ.	Max.	Unit	Condition
V _{SUP}	Supply Voltage	VSUPx	4.5 5.7	5 6.0	5.5 6.5	V	Normal Operation During Programming
I _{OUT}	Continuous Output Current	OUTx		–	5.5	mA	
R _L	Load Resistor	OUTx	1	–	–	kΩ	R _{pull-up} > 1 kΩ R _{pull-down} > 5 kΩ
N _{PRG}	Number of Memory Programming Cycles	–	–	–	100	cycles	0 °C < T _{amb} < 55 °C
B _{AMP}	Recommended Magnetic Field Amplitude	–	±20	-	±100	mT	
T _J	Junction Temperature ¹⁾	–	–40	–	170	°C	for 1000 hrs
T _A	Ambient Temperature ²⁾	–	–40	–	150	°C	

¹⁾ Depends on the temperature profile of the application. Please contact TDK-Micronas for life time calculations.
²⁾ Consider current consumption, mounting condition (e.g. overmold, potting) and mounting situation for T_A and in relation to T_J

Note It is possible to operate the sensor with magnetic fields down to ±5 mT. For magnetic fields below ±20 mT the sensor performance will be reduced.

4.9. Characteristics

At $T_A = -40\text{ °C}$ to 150 °C , $V_{SUP} = 4.5\text{ V}$ to 5.5 V , $GND = 0\text{ V}$, after programming and locking of the sensor, at Recommended Operation Conditions if not otherwise specified in the column “Test Conditions”.

Typical Characteristics for $T_J = 25\text{ °C}$ and $V_{SUP} = 5\text{ V}$.

Symbol	Parameter	Pin Name	Limit Values			Unit	Test Conditions
			Min.	Typ.	Max.		
I_{SUP}	Supply Current over Temperature Range	VSUPx	–	8	12	mA	Current consumption of each die
	Resolution ¹⁾	OUTx	–	12	–	bit	depends on PWM Period
$t_{startup}$	Start-up Time ²⁾	OUTx	–	1.4	1.8	ms	(see Fig. 4–3 on page 44) LP_FILTER = OFF
Overvoltage and Undervoltage Detection							
$V_{SUP,UV}$	Undervoltage Detection Level	VSUPx	3.3 3.1	3.9 3.7	4.3 4.1	V V	Functionality Mode: Normal Functionality Mode: Extended CUST_SETUP1 register bit 5
$V_{SUP,UVhyst}$	Undervoltage Detection Level Hysteresis ²⁾	VSUPx	–	200	–	mV	
$V_{SUP,OV}$	Overvoltage Detection Level	VSUPx	5.6 8.5	6.2 9.5	6.9 10.4	V V	Functionality Mode: Normal Functionality Mode: Extended CUST_SETUP1 register bit 5
$V_{SUP,OVhyst}$	Overvoltage Detection Level Hysteresis ²⁾	VSUPx	–	225	–	mV	
Output Voltage in Case of Error Detection							
$V_{SUP,DIAG}$	Supply Voltage required to get defined Output Voltage Level ²⁾	VSUPx	–	2.3	–	V	The output will be ‘low’ for $V_{SUP,DIAG} < V_{SUP} < V_{SUP,UV}$
$V_{Error,Low}$	Output Voltage Range of Lower Error Band ²⁾	OUTx	0	–	4	% V_{SUP}	$V_{SUP} > V_{SUP,UV}$ $R_{pull-up} > 5\text{ k}\Omega$ ERROR_BAND bit 7 = 1 in CUST_SETUP1
$V_{Error,High}$	Output Voltage Range of Upper Error Band ²⁾	OUTx	96	–	100	% V_{SUP}	$V_{SUP} > V_{SUP,UV}$ ERROR_BAND bit 7 = 0 in CUST_SETUP1
¹⁾ Guaranteed by Design ²⁾ Characterized on small sample size, not tested.							

Symbol	Parameter	Pin Name	Limit Values			Unit	Test Conditions
			Min.	Typ.	Max.		
Push-Pull Configuration							
V _{OUTH}	Output High Voltage	OUTx	4.8	4.9	–	V	V _{SUP} = 5 V, R _{LPull-up/down} = 5 kΩ
V _{OUTL}	Output Low Voltage	OUTx	–	0.1	0.2	V	V _{SUP} = 5 V, R _{LPull-up/down} = 5 kΩ
V _{OUTL}	Output Low Voltage ²⁾	OUTx	–	0.4	0.65	V	V _{SUP} = 5 V, R _{LPull-up} = 1 kΩ
t _{rise}	Rise Time of Digital Output ²⁾	OUTx	–	0.2	0.5	μs	V _{SUP} = 5 V, R _{LPull-up} = 1 kΩ C _L = 1 nF
t _{fall}	Fall Time of Digital Output ²⁾	OUTx	–	0.25	0.5	μs	V _{SUP} = 5 V, R _{LPull-up} = 1 kΩ C _L = 1 nF
ROUT_DIG	On Resistance of Digital Push-Pull Driver	OUTx	–	100	200	Ω	
Open-Drain Configuration							
I _{OH}	Output Leakage Current	OUTx	–50	10	500	μA	
V _{OL}	Output Low Voltage ²⁾	OUTx	–	0.1	0.2	V	V _{SUP} = 5 V, R _{LPull-up} = 5 kΩ
			–	0.4	0.65	V	V _{SUP} = 5 V, R _{LPull-up} = 1 kΩ
t _{rise}	Rise Time of Digital Output ²⁾	OUTx	–	4.2	5.3	μs	V _{SUP} = 5 V R _{LPull-up} = 1 kΩ C _L = 1 nF
t _{fall}	Fall Time of Digital Output ²⁾	OUTx	–	0.25	0.5	μs	V _{SUP} = 5 V, R _{LPull-up} = 1 kΩ C _L = 1 nF
PWM Output							
t _{OSD}	Overall Signal Delay ¹⁾²⁾	OUTx	–	0.312	0.343	ms	Overall signal delay between sensor front-end and output. Transmission time of selected PWM frequency to be added. For 8 kHz sample frequency
OUT _{Noise}	Output Noise RMS ²⁾	OUTx	–	0.03	0.08	%	Min. magnetic ampl. = ±20 mT Related to 100% duty cycle
f _{PWM}	PWM Frequency	OUTx	1800 1440 900 720 450 360 225 180	–	2200 1760 1100 880 550 440 275 220	Hz	Customer programmable
J _{PWM}	RMS PWM Jitter ²⁾	OUTx	–	1	2	LSB ₁₂	f _{PWM} = 1 kHz
¹⁾ Guaranteed by Design ²⁾ Characterized on small sample size, not tested.							

Symbol	Parameter	Pin Name	Limit Values			Unit	Test Conditions
			Min.	Typ.	Max.		
SENT Output							
$\Delta T_{osc}/T_{osc}$	Clock Accuracy	OUTx	-10	0	10	%	On clock tick time without pause pulse
t_{nlow}	Sensor pulse low time	OUTx	-	5	-	t_{tick}	
SOIC8 Package							
						(Self-heating calculation see Section 5.1. on page 47)	
R_{thja}	Thermal Resistance Junction to Air	-	-	-	116	K/W	Determined with a 1S1P board
		-	-	-	111	K/W	Determined with a 2S2P board
R_{thjc}	Thermal Resistance Junction to Case	-	-	-	30	K/W	Determined with a 1S1P and a 2S2P board
R_{ISOL}	Isolation Resistance	GND1, GND2	4	-	-	Ω	Between two dies (Between GND1 and GND2 pin)

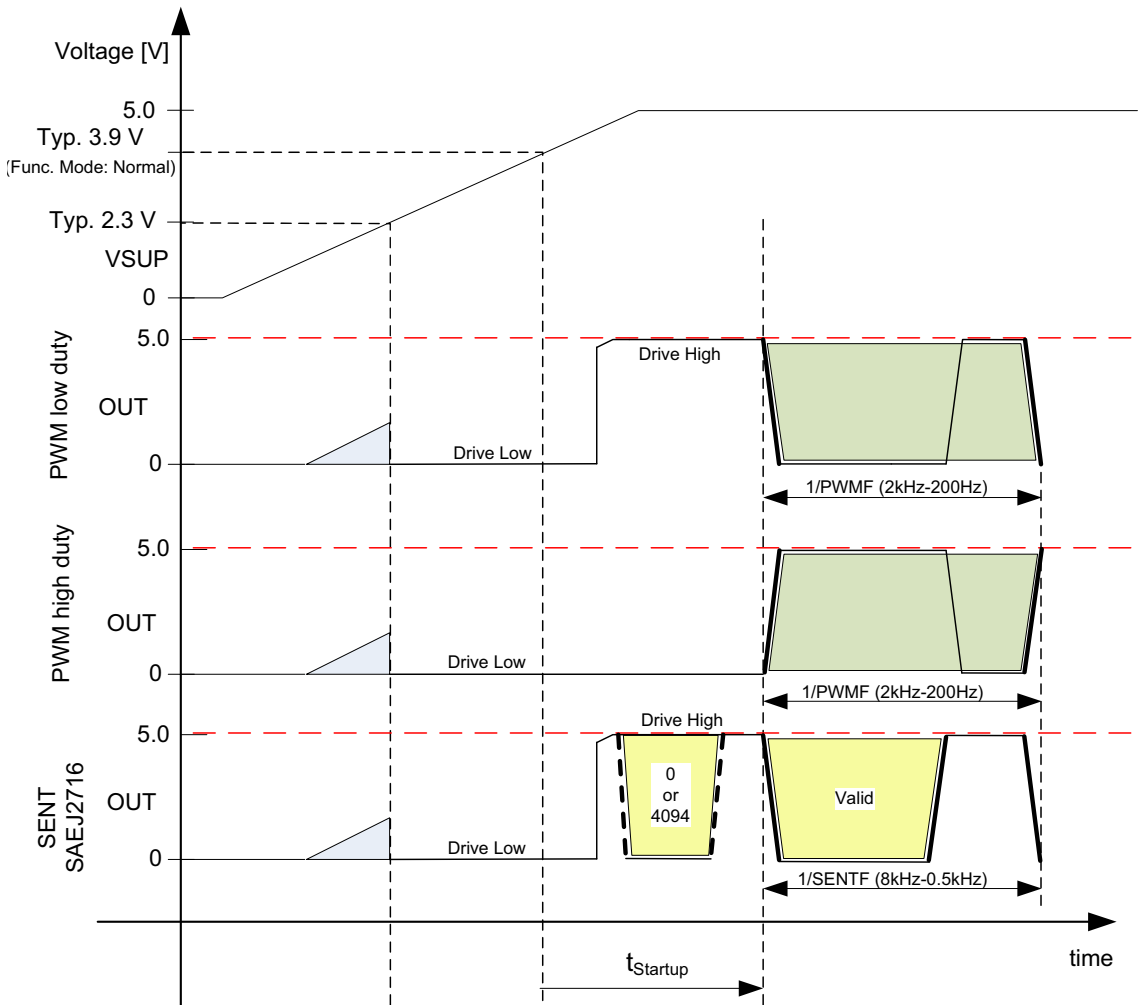

Fig. 4-3: Startup behavior of HAR 379x in different output modes

4.10. Magnetic Characteristics

At $T_A = -40\text{ °C}$ to 150 °C , $V_{SUP} = 4.5\text{ V}$ to 5.5 V , $GND = 0\text{ V}$, after programming and locking of the sensor, at Recommended Operation Conditions if not otherwise specified in the column "Test Conditions". Typical Characteristics for $T_J = 25\text{ °C}$ and $V_{SUP} = 5\text{ V}$.

Symbol	Parameter	Pin No.	Min.	Typ.	Max	Unit	Test Conditions
Θ_{RANGE}	Detectable angle range	OUTx	0	–	360	°	
Θ_{res}	Angle resolution	OUTx	–	–	0.09	°	($360^\circ/4096$)
$E_{\Theta linxy}$	X/Y angle linearity error over temperature (on output of CORDIC filter)	OUTx	–1.7	–	1.7	°	Min. $B_{AMP} = \pm 30\text{ mT}$ ^{1) 2)} ₃₎
			–2.4	–	2.4	°	Min. $B_{AMP} = \pm 20\text{ mT}$ ^{1) 2)} ₃₎
$ASMm_{X/Y_Z}$	Absolute sensitivity mismatch on raw signals between X/Y and Z channel	OUTx	–3.0	–	3.0	%	$T_J = 25\text{ °C}^{1)}$
$Sense_{XYZ}$	Sensitivity of X/Y and Z Hall Plate	OUTx	117	130	143	LSB/ mT	$T_J = 25\text{ °C}^{1)}$
SMm_{X/Y_Z}	Thermal sensitivity mismatch drift of calibrated signals between X/Y and Z channel	OUTx	–2.5	–	2.5	%	over full temperature range related to $25\text{ °C}^{1)}$
SMm_{XY}	Thermal sensitivity mismatch drift of calibrated signals between X and Y channel	OUTx	–2.0	–	2.0	%	over full temperature range related to $25\text{ °C}^{1)}$
$Offset_{XY}$	Offset of calibrated signals of X or Y channel	OUTx	–20	–	20	LSB ₁₅	$T_J = 25\text{ °C}^{1)}$ Can be compensated in customer application
$Offset_Z$	Offset of calibrated signal of Z channel	OUTx	–20	–	20	LSB ₁₅	$T_J = 25\text{ °C}^{1)}$ Can be compensated in customer application
$\Delta Offset_{XY}$	Offset drift of calibrated signals of X or Y channel	OUTx	–70	–	70	LSB ₁₅	over full temperature range related to $25\text{ °C}^{1)}$
$\Delta Offset_Z$	Offset drift of calibrated signals of Z channel	OUTx	–20	–	20	LSB ₁₅	over full temperature range related to $25\text{ °C}^{1)}$
¹⁾ Characterized on sample base, 3-sigma values, not tested for each device ²⁾ Calculated angular error based on characterization and not on single error summation ³⁾ After optimal EOL calibration at room temperature							

Symbol	Parameter	Pin No.	Min.	Typ.	Max	Unit	Test Conditions
E_{Phase}	Magnetic Angle Phase Error ^{1) 4)}	OUTx	-	± 1.1	-	$^{\circ}$	XY axis
			-	± 1.1	-	$^{\circ}$	XZ axis
			-	± 1.1	-	$^{\circ}$	YZ axis
$\Delta SM_{\text{XYZlife}}$	Relative sensitivity mismatch drift of calibrated signals between X or Y and Z channel over life time	OUTx	-	1.0	-	%	after 1000h HTOL ¹⁾
$\Delta \text{Offset}_{\text{XYlife}}$	Offset drift of calibrated signals of X or Y channel over life time	OUTx	-	30	-	LSB ₁₅	after 1000h HTOL ¹⁾
$\Delta \text{Offset}_{\text{Zlife}}$	Offset drift of calibrated signal of Z channel over life time	OUTx	-	± 15	-	LSB ₁₅	after 1000h HTOL ¹⁾
¹⁾ Characterized on sample base, 3-sigma values, not tested for each device ⁴⁾ Can be compensated by setpoint linearization							

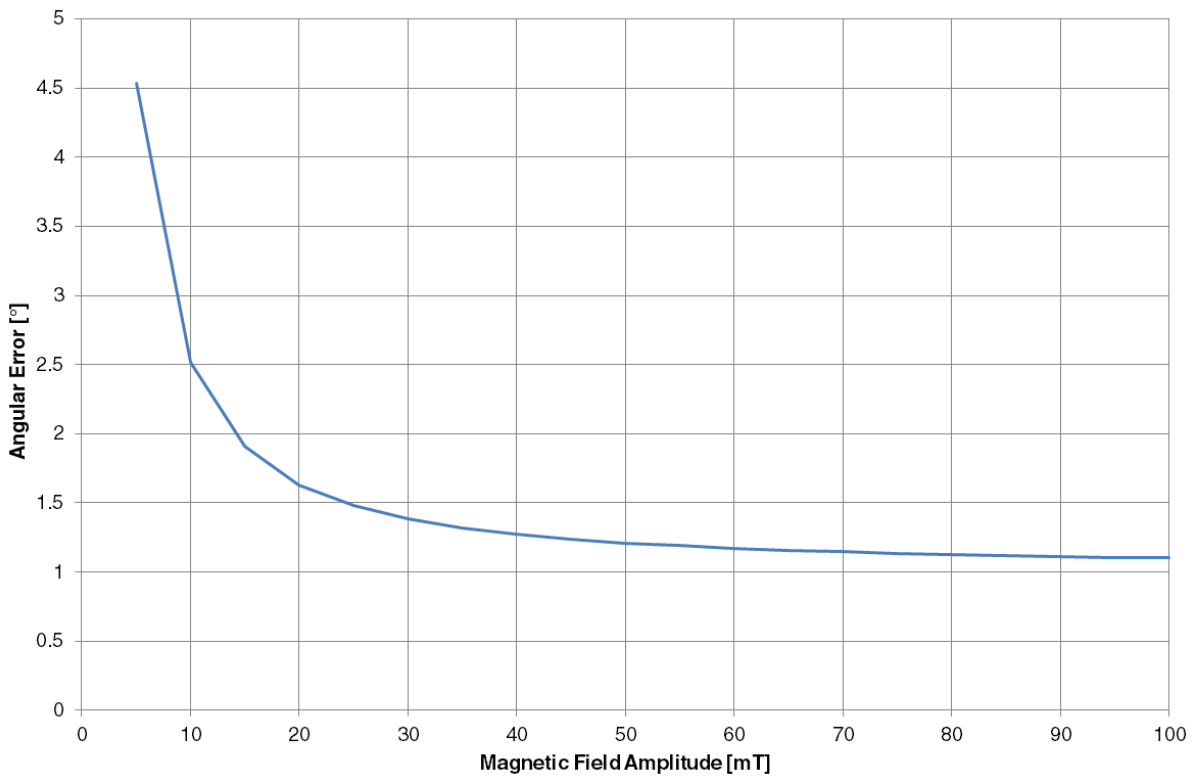

Fig. 4-4: Angular error versus magnetic field amplitude over full temperature range for devices using X and Y magnetic field component

5. Application Notes

5.1. Ambient Temperature

Due to the internal power dissipation, the temperature on the silicon chip (junction temperature T_J) is higher than the temperature outside the package (ambient temperature T_A).

$$T_J = T_A + \Delta T$$

At static conditions and continuous operation, the following equation applies:

$$\Delta T = I_{SUP} * V_{SUP} * R_{thjX}$$

The X represents junction to air, case or solder point.

For worst case calculation, use the max. parameters for I_{SUP} and R_{thjX} , and the max. value for V_{SUP} from the application.

Example for calculation of self-heating ΔT

The following example shows the result for junction to air conditions for SOIC8 package:

$V_{SUP} = 5.5 \text{ V}$, $R_{thja} = 111 \text{ K/W}$ and $I_{SUP} = 24 \text{ mA}$ (two dies) the temperature difference $\Delta T = 14.7 \text{ K}$.

The junction temperature T_J is specified. The maximum ambient temperature T_{Amax} can be calculated as:

$$T_{Amax} = T_{Jmax} - \Delta T$$

Note The calculated self-heating of the device is only valid for the Rth test boards. Depending on the application setup the final results in an application environment might deviate from these values.

5.2. EMC and ESD

Please contact TDK-Micronas for detailed information on EMC and ESD performance.

5.3. Application Circuits

PWM Output

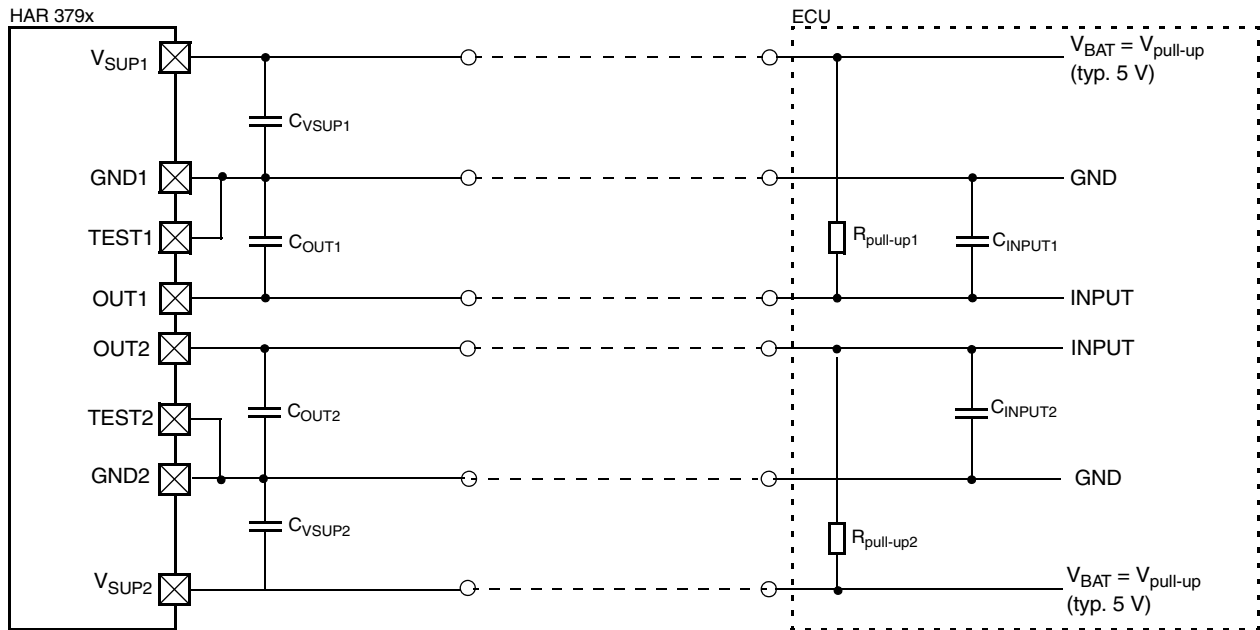

Fig. 5-1: Recommended application circuit in PWM mode

- $C_{VSUP1} = C_{VSUP2} = 100 \text{ nF}$
- $C_{OUT1} = C_{OUT2} = 1 \text{ nF}$

SAEJ2716 SENT Output

In case of SAEJ2716 SENT output mode, it is recommended to add a filter structure at the output pin for having a SENT standard compliant output slew rate.

The following two setups have been tested (with Push-Pull output configuration):

- $C_{VSUP1} = C_{VSUP2} = 100 \text{ nF}$
- $C_{OUT1} = C_{OUT2} = 1 \text{ nF}$
- $C_{INPUT1} = C_{INPUT2} = 68 \text{ pF}$
- $C_{Tau1} = C_{Tau2} = 2.2 \text{ nF}$
- $R_{Tau1} = R_{Tau2} = 560 \text{ Ohm}$
- $R_{Pull-Up1} = R_{Pull-Up2} = 10 \text{ kOhm}$

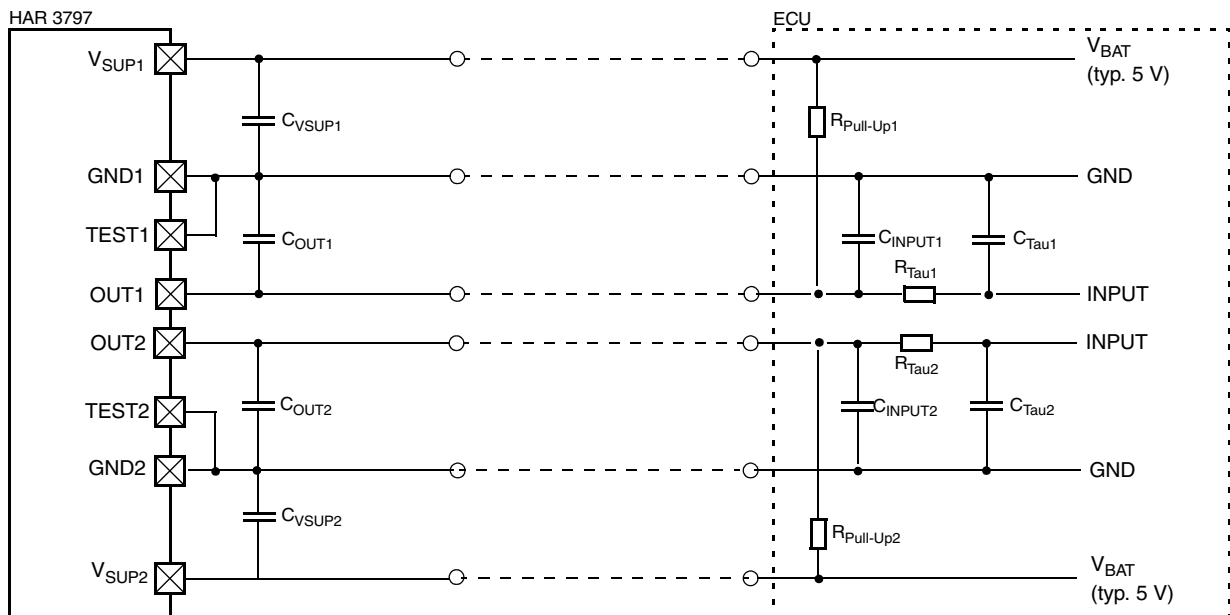

Fig. 5–2: Recommended application circuit in SENT output mode

5.4. Measurement of a PWM Output Signal

In case of PWM output, the magnetic field information is coded in the duty cycle of the PWM signal. The duty cycle is defined as the ratio between the high time “s” and the period “d” of the PWM signal (see Fig. 5–3).

Note The PWM signal is either updated with the falling or rising edge depending on the settings of bit 3 in the Customer Setup 2 register.

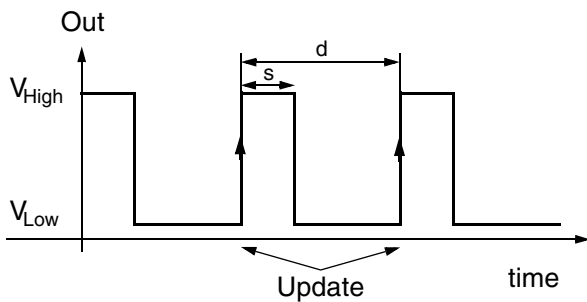

Fig. 5–3: Definition of PWM signal (Bit 3 in customer setup register 2 is set to update with rising edge.)

6. Programming of the Sensor

HAR 379x features two different customer modes. In **Application Mode** the sensors provides a digital output signal (PWM or SENT). In **Programming Mode** it is possible to change the register settings of the sensor.

After power-up the sensor is always operating in the **Application Mode**. It is switched to the **Programming Mode** by a pulse at the sensor output pin.

6.1. Programming Interface

In Programming Mode HAR 379x is addressed by modulating a serial telegram on the sensors output pin. The sensor answers with a modulation of the output voltage.

A logical “0” is coded as no level change within the bit time. A logical “1” is coded as a level change of typically 50% of the bit time. After each bit, a level change occurs (see Fig. 6–1).

The serial telegram is used to transmit the EEPROM content, error codes and digital values of the angle information from and to the sensor.

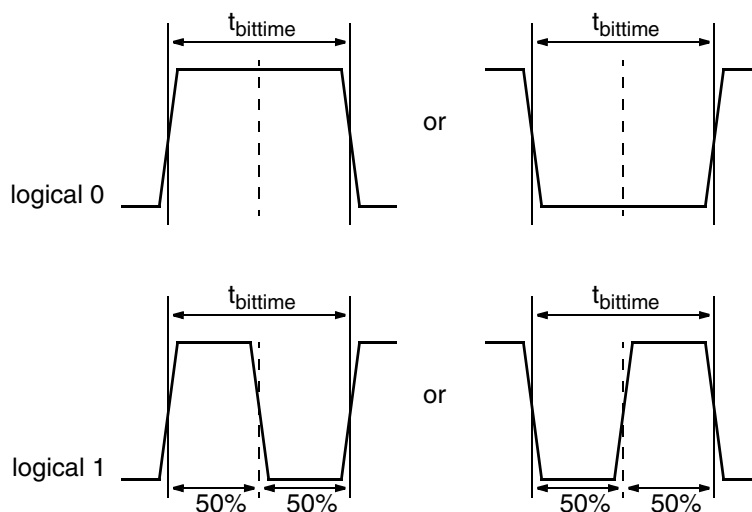

Fig. 6–1: Definition of logical 0 and 1 bit

A description of the communication protocol and the programming of the sensor is available in a separate document (Application Note: HAR 379x Programming Guide).

Table 6–1: Telegram parameters (All voltages are referenced to GND.)

Symbol	Parameter	Pin	Limit Values			Unit
			Min.	Typ.	Max.	
V_{OUTL}	Sensor OUT Pin voltage for low level during programming	OUTx	–	–	10	%VSUP
V_{OUTH}	Voltage for Output High Level during Programming through Sensor Output Pin	OUTx	90	–	–	%VSUP
$V_{SUPProgram}$	V_{SUP} Voltage for EEPROM programming (during Programming)	VSUPx	5.7	6.0	6.5	V
	Slew rate	OUTx	–	2	–	V/ μ s

6.2. Programming Environment and Tools

For the programming of HAR 379x during product development a programming tool including hardware and software is available on request. It is recommended to use the TDK-Micronas tool kit (TDK-MSP V1.0 or USB kit and Lab View Programming Environment) in order to facilitate the product development. The details of programming sequences are also available on request.

6.3. Programming Information

For production and qualification tests, it is mandatory to set the LOCK bit to one after final adjustment and programming of HAR 379x.

Before locking the device, it is recommended to read back all register values to ensure that the intended data is correctly stored in the sensor's memory. Alternatively, it is also possible to cross-check the sensor output signal with the intended output behavior.

The success of the LOCK process shall be checked by reading the status of the LOCK bit after locking.

Even after locking the device it is still possible to read the memory content.

It is also mandatory to check the acknowledge (first and second) of the sensor after each write and store sequence to verify if the programming of the sensor was successful. To enable debugging of the production line, it is recommended to read back the PROG_DIAGNOSIS register in case of a missing second acknowledge.

Electrostatic Discharges (ESD) may disturb the programming pulses. Please take precautions against ESD.

7. Document History

1. Advance Information: "HAR 379x Robust Dual-Die Programmable 2D Position Sensor Family with PWM/SENT Output", Aug. 17, 2017, AI000203_001EN. First release of the advance information.
2. Data Sheet: "HAR 379x Robust Dual-Die Programmable 2D Position Sensor Family with PWM/SENT Output", March 27, 2019, DSH000203_001EN. First release of the data sheet.

Major Changes:

- DNC filter registers renamed
- Maximum ratings: Values updated
- Electric and magnetic characteristics updated