

Data Sheet

HAL[®] 1002

Highly Precise Programmable
Hall-Effect Switch

Copyright, Warranty, and Limitation of Liability

The information and data contained in this document are believed to be accurate and reliable. The software and proprietary information contained therein may be protected by copyright, patent, trademark and/or other intellectual property rights of TDK-Micronas. All rights not expressly granted remain reserved by TDK-Micronas.

TDK-Micronas assumes no liability for errors and gives no warranty representation or guarantee regarding the suitability of its products for any particular purpose due to these specifications.

By this publication, TDK-Micronas does not assume responsibility for patent infringements or other rights of third parties which may result from its use. Commercial conditions, product availability and delivery are exclusively subject to the respective order confirmation.

Any information and data which may be provided in the document can and do vary in different applications, and actual performance may vary over time.

All operating parameters must be validated for each customer application by customers' technical experts. Any mention of target applications for our products is made without a claim for fit for purpose as this has to be checked at system level.

Any new issue of this document invalidates previous issues. TDK-Micronas reserves the right to review this document and to make changes to the document's content at any time without obligation to notify any person or entity of such revision or changes. For further advice please contact us directly.

Do not use our products in life-supporting systems, military, aviation, or aerospace applications! Unless explicitly agreed to otherwise in writing between the parties, TDK-Micronas' products are not designed, intended or authorized for use as components in systems intended for surgical implants into the body, or other applications intended to support or sustain life, or for any other application in which the failure of the product could create a situation where personal injury or death could occur.

No part of this publication may be reproduced, photocopied, stored on a retrieval system or transmitted without the express written consent of TDK-Micronas.

TDK-Micronas Trademarks

– HAL

TDK-Micronas Patents

US 6 968 484, EP 1 039 357, EP 1 575 013, EP 1 949 034

Third-Party Trademarks

All other brand and product names or company names may be trademarks of their respective companies.

Contents

Page	Section	Title
4	1.	Introduction
5	1.1.	Major Applications
5	1.2.	Features
6	2.	Ordering Information
6	2.1.	Device-Specific Ordering Codes
7	3.	Functional Description
7	3.1.	General Function
9	3.2.	Digital Signal Processing and EEPROM
15	3.3.	General Calibration Procedure
17	3.4.	Example: Calibration of a Position Switch
19	4.	Specifications
19	4.1.	Outline Dimensions
23	4.2.	Soldering, Welding and Assembly
23	4.3.	Pin Connections and Short Descriptions
23	4.4.	Dimension of Sensitive Area
24	4.5.	Absolute Maximum Ratings
24	4.6.	Storage and Shelf Life
25	4.7.	Recommended Operating Conditions
26	4.8.	Characteristics
27	4.9.	Magnetic Characteristics
28	5.	Application Notes
28	5.1.	Application Circuit
29	5.2.	Temperature Compensation
31	5.3.	Ambient Temperature
31	5.4.	EMC and ESD
32	6.	Programming
32	6.1.	Definition of Programming Pulses
32	6.2.	Definition of the Telegram
35	6.3.	Telegram Codes
36	6.4.	Number Formats
37	6.5.	Register Information
40	6.6.	Programming Information
41	7.	Document History

Highly Precise Programmable Hall-Effect Switch

Release Note: Revision bars indicate significant changes to previous version

1. Introduction

The HAL 1002 is the improved successor of the HAL 1000 Hall-effect switch. The major sensor characteristics, the two switching points B_{ON} and B_{OFF} , are programmable for the application. The sensor can be programmed to be unipolar or latching, sensitive to the magnetic north pole or sensitive to the south pole, with normal or with an electrically inverted output signal. Several examples are shown in Fig. 3–4 through Fig. 3–7.

The HAL1002 is based on the HAL83x family and features a temperature-compensated Hall plate with chopper offset compensation, an A/D converter, digital signal processing, a push-pull output stage, an EEPROM memory with redundancy and Lock function for the calibration data, a serial interface for programming the EEPROM, and protection devices at all pins. Internal digital signal processing is of great benefit because analog offsets, temperature shifts, and mechanical stress effects do not degrade the sensor accuracy.

The HAL1002 is programmable by modulating the supply voltage. No additional programming pin is needed. Programming is simplified through the use of a two-point calibration. Calibration is accomplished by adjusting the sensor output directly to the input signal. Individual adjustment of each sensor during the customer's manufacturing process is possible. With this calibration procedure, the tolerances of the sensor, the magnet, and the mechanical positioning can be compensated for the final assembly. This offers a low-cost alternative for all applications that presently require mechanical adjustment or other system calibration.

In addition, the temperature compensation of the Hall-effect Integrated Circuit (IC) can be tailored to all common magnetic materials by programming first and second order temperature coefficients of the Hall-effect sensor's sensitivity. This enables operation over the full temperature range with constant switching points.

The calculation of the individual sensor characteristics and the programming of the EEPROM memory can easily be done with a PC and the application kit from TDK-Micronas.

The sensor is designed and produced in sub-micron CMOS technology for the use in hostile industrial and automotive applications with nominal supply voltage of 5 V in the ambient temperature range from $-40\text{ }^{\circ}\text{C}$ up to $150\text{ }^{\circ}\text{C}$.

■ The HAL 1002 is available in the leaded package TO92UT.

1.1. Major Applications

Due to the sensor's versatile programming characteristics, the HAL 1002 is a potential solution for applications which require very precise contactless switching:

- Endpoint detection
- Level switch (e.g. liquid level)
- Electronic fuse (current measurement)

1.2. Features

- High-precision Hall-effect switch with programmable switching points and switching behavior
- AEC-Q100 qualified
- EMC and ESD optimized design
ESD HBM performance >7 kV
- Switching points programmable from –150 mT up to 150 mT in steps of 0.5% of the magnetic-field range
- Multiple programmable magnetic characteristics in a non-volatile memory (EEPROM) with redundancy and Lock function
- Temperature characteristics are programmable for matching all common magnetic materials
- Programming through modulation of the supply voltage
- Operates from –40 °C up to 150 °C ambient temperature
- Operates from 4.5 V up to 8.5 V supply voltage in specification and functions up to 11 V
- Operates with static magnetic fields and dynamic magnetic fields up to 2 kHz
- Extremely robust magnetic characteristics against mechanical stress
- Overvoltage and reverse-voltage protection at all pins
- Short-circuit protected push-pull output

2. Ordering Information

A Micronas device is available in a variety of delivery forms. They are distinguished by a specific ordering code:

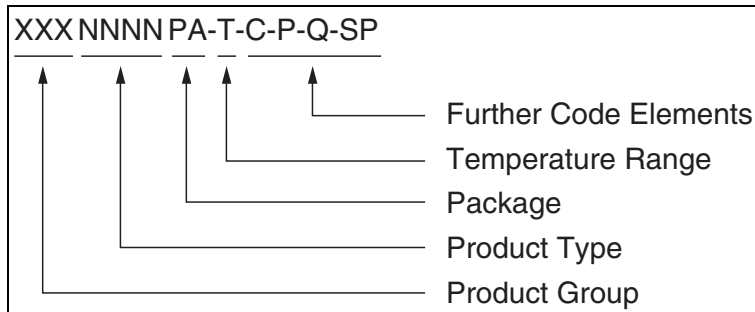

Fig. 2–1: Ordering code principle

For a detailed information, please refer to the brochure: “Sensors and Controllers: Ordering Codes, Packaging, Handling”.

2.1. Device-Specific Ordering Codes

HAL 1002 is available in the following package and temperature variants.

Table 2–1: Available packages

Package Code (PA)	Package Type
UT	TO92UT-1 (spread)
UT	TO92UT-2 (in-line)

Table 2–2: Available temperature ranges

Temperature Code (T)	Temperature Range
A	$T_J = -40\text{ °C to }170\text{ °C}$

The relationship between ambient temperature (T_A) and junction temperature (T_J) is explained in Section 5.3. on page 31.

For available variants for Configuration (C), Packaging (P), Quantity (Q), and Special Procedure (SP) please contact TDK-Micronas.

Table 2–3: Available ordering codes and corresponding package marking

Available Ordering Code	Package Marking
HAL 1002UT-A-[C-P-Q-SP]	1002A

3. Functional Description

3.1. General Function

The HAL 1002 is a monolithic Integrated Circuit (IC) which provides a digital output signal in response to an magnetic input signal. The sensor is based on the HAL83x design.

The Hall plate is sensitive to magnetic north and south polarity. The external magnetic-field component perpendicular to the branded side of the package generates a Hall voltage. This voltage is converted to a digital value and processed in the Digital Signal Processing unit (DSP) according to the settings of the EEPROM registers. The function and the parameters for the DSP are explained in Section 3.2. on page 9.

The setting of the LOCK register disables the programming of the EEPROM memory for all time. This register cannot be reset.

As long as the LOCK register is not set, the output characteristic can be adjusted by programming the EEPROM registers. The IC is addressed by modulating the supply voltage (see Fig. 3–1). After detecting a command, the sensor reads or writes the memory and answers with a digital signal on the output pin. The output of the sensor does react to a magnetic field during the communication.

Internal temperature compensation circuitry and the spinning current offset compensation enable the operation over the full temperature range with minimal changes of the switching points. The circuitry also rejects offset shifts due to mechanical stress from the package. The non-volatile memory consists of redundant EEPROM cells. In addition, the HAL1002 is equipped with devices for overvoltage and reverse-voltage protection at all pins.

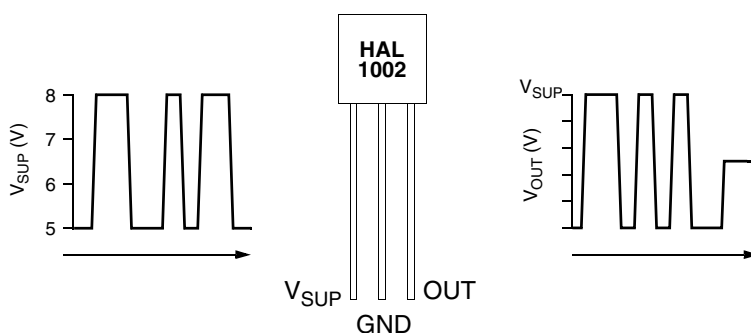

Fig. 3–1: Programming with V_{SUP} modulation

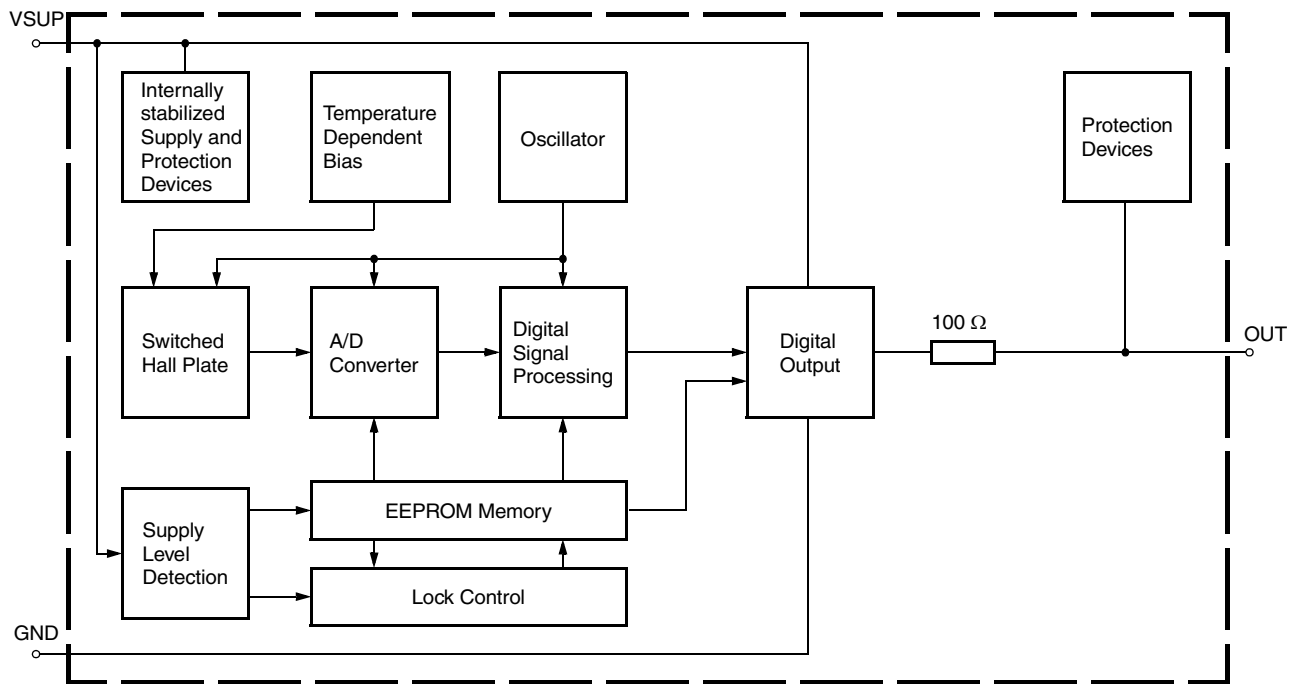

Fig. 3–2: HAL 1002 block diagram

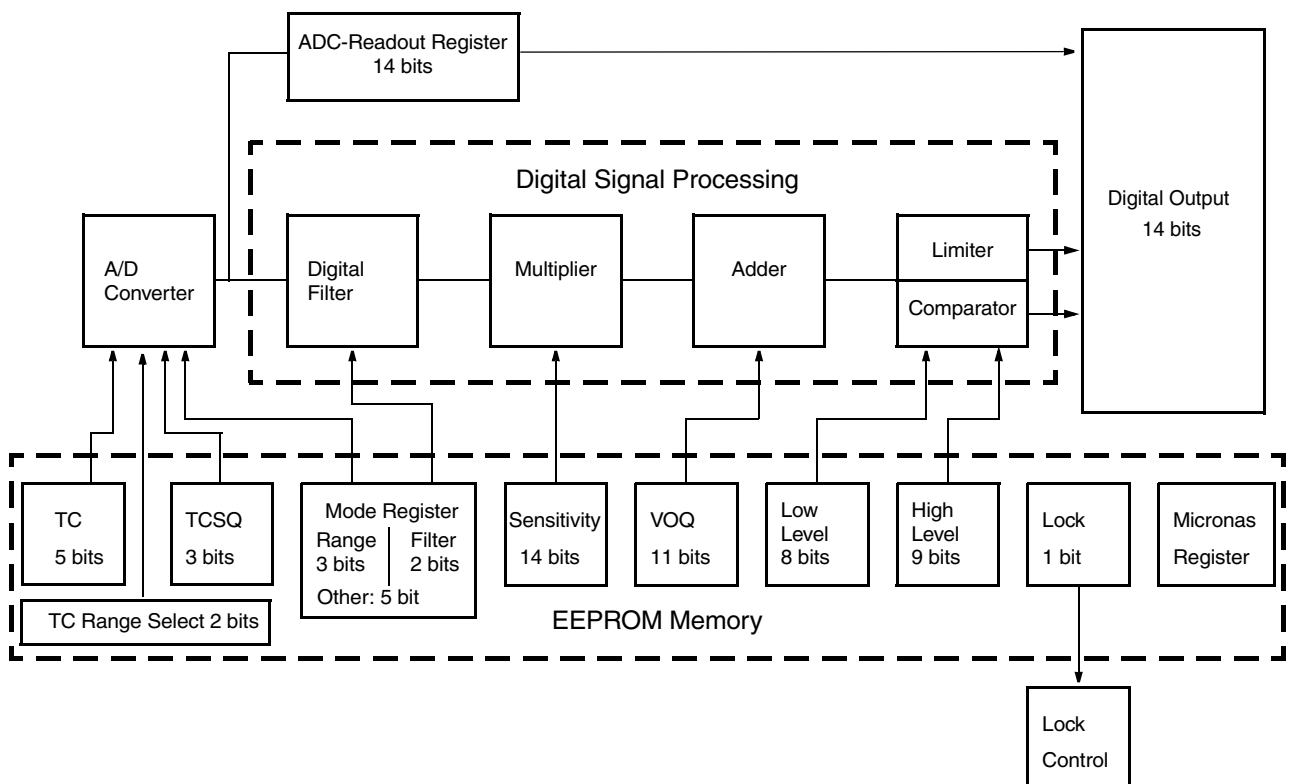

Fig. 3–3: Details of EEPROM registers and digital signal processing

3.2. Digital Signal Processing and EEPROM

Note In this section the digital signal processing is described for a linear sensor on which the HAL1002 is based.

The DSP is the main part of the sensor and performs the signal processing. The parameters for the DSP are stored in the EEPROM registers. The details are shown in Fig. 3–3.

Terminology:

SENSITIVITY: name of the register or register value

Sensitivity: name of the parameter

EEPROM Registers:

The EEPROM registers include three groups:

Group 1 contains the registers for the adaptation of the sensor to the magnetic system: MODE for selecting the magnetic-field range and filter frequency, TC and TCSQ for the temperature characteristics of the magnetic sensitivity and thereby for the switching points.

Group 2 contains the registers for defining the switching points: SENSITIVITY, VOQ, LOW-LEVEL, and HIGH-LEVEL.

The comparator compares the processed signal voltage with the reference values Low-Level and High-Level.

The output switches on (low) if the signal voltage is higher than the High-Level, and switches off (high) if the signal falls below the Low-Level. Several examples of different switching characteristics are shown in Fig. 3–4 to Fig. 3–7.

- The parameter V_{OQ} (Output Quiescent Voltage) corresponds to the signal voltage at $B = 0$ mT.
- The parameter Sensitivity defines the magnetic sensitivity:

$$Sensitivity = \frac{\Delta V_{Signal}}{\Delta B}$$

- The signal voltage can be calculated as follows:

$$V_{Signal} \sim Sensitivity \times B + V_{OQ}$$

Therefore, the switching points are programmed by setting the SENSITIVITY, VOQ, LOW-LEVEL, and HIGH-LEVEL registers. The available TDK-Micronas software calculates the best parameter set respecting the ranges of each register.

Group 3 contains TDK-Micronas registers and LOCK for the locking of all registers. The TDK-Micronas registers are programmed and locked during production and are read-only for the customer. These registers are used for oscillator frequency trimming, A/D converter offset compensation, and several other special settings.

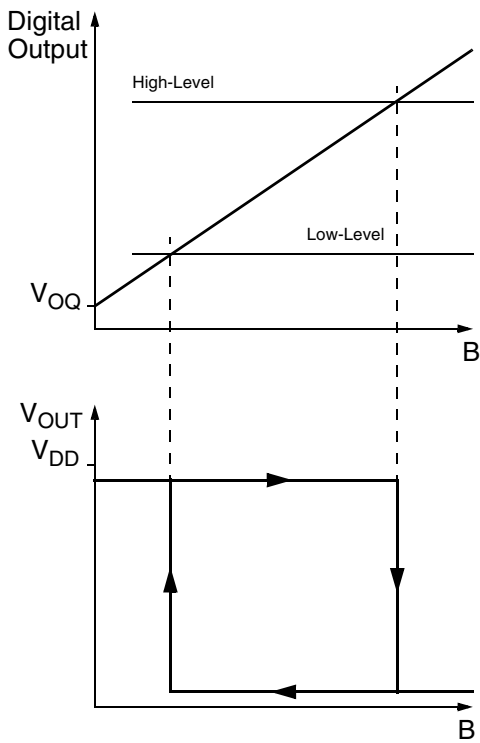

Fig. 3-4: HAL 1002 with unipolar behavior

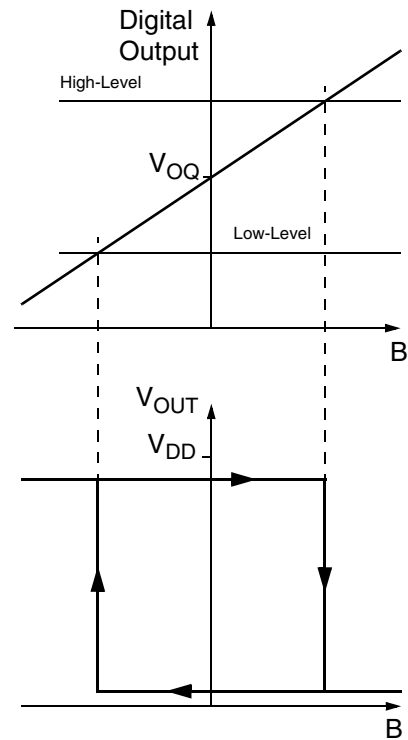

Fig. 3-5: HAL 1002 with latching behavior

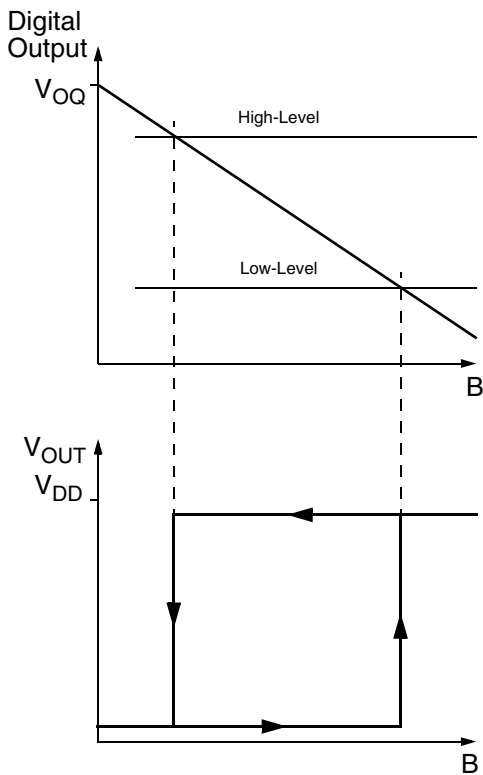

Fig. 3-6: HAL 1002 with unipolar inverted behavior

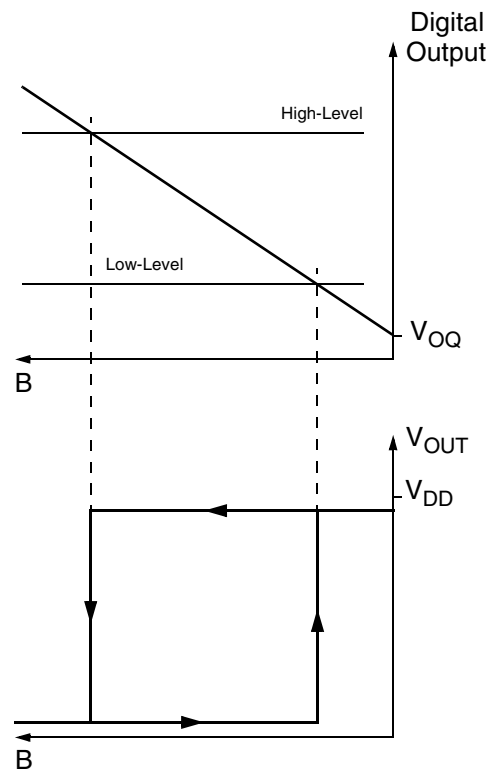

Fig. 3-7: HAL 1002 with unipolar behavior sensitive to the other magnetic polarity

MODE register

The MODE register contains all bits used to configure the A/D converter and the different output modes.

Table 3–1: MODE register

MODE										
Bit Number	9	8	7	6	5	4	3	2	1	0
Parameter	RANGE	Reserved	OUTPUT-MODE			FILTER		RANGE (together with bit 9)		Reserved

Magnetic Range

The RANGE bits define the magnetic-field range of the A/D converter.

Table 3–2: RANGE bits

Magnetic Range	RANGE	
	MODE [9]	MODE [2:1]
±15 mT	1	00
±30 mT	0	00
±60 mT	0	01
±80 mT	0	10
±100 mT	0	11
±150 mT	1	11

Filter

The FILTER bits define the –3 dB frequency of the digital low pass filter.

Table 3–3: FILTER bits

–3 dB Frequency	MODE [4:3]
80 Hz	00
500 Hz	10
1 kHz	11
2 kHz	01

Output Format

The OUTPUTMODE bits define the different output modes of HAL 83x.

Table 3–4: Output formats

Output Format	MODE [7:5]
Switch (positive polarity)	100
Switch (negative polarity)	101

TC Register

The temperature dependence of the magnetic sensitivity can be adapted to different magnetic materials in order to compensate for the change of the magnetic strength with temperature. The adaptation is done by programming the TC (Temperature Coefficient) and the TCSQ registers (Quadratic Temperature Coefficient). Thereby, the slope and the curvature of the temperature dependence of the magnetic sensitivity can be matched to the magnet and the sensor assembly. As a result, the output voltage characteristic can be constant over the full temperature range. The sensor can compensate for linear temperature coefficients ranging from about -3100 ppm/K up to 1000 ppm/K and quadratic coefficients from about -7 ppm/K² to 2 ppm/K².

The full TC range is separated in the following four groups:

Table 3–5: TC register

TC-Register											
Bit Number	9	8	7	6	5	4	3	2	1	0	
Parameter	TC-RANGE		TC					TCSQ			

Table 3–6: TC ranges

TC Range [ppm/k]	TC-Range Group
-3100 to -1800 (not for ± 15 mT range)	0
-1750 to -550 (not for ± 15 mT range)	2
-500 to $+450$ (default value)	1
$+450$ to $+1000$	3

TC (5 bits) and TCSQ (3 bits) have to be selected individually within each of the four ranges. For example 0 ppm/k requires TC-Range = 1, TC = 15 and TCSQ = 1. Please refer to Section 5.2. on page 29 for more details.

Sensitivity Register

The SENSITIVITY register contains the parameter for the multiplier in the DSP. Sensitivity is programmable between -4 and 4 in steps of 0.00049 .

VOQ Register

The VOQ register contains the parameter for the adder in the DSP. V_{OQ} is the signal voltage without external magnetic field ($B = 0$ mT, respectively $ADC-READOUT = 0$) and programmable from $-V_{SUP}$ up to V_{SUP} . For $V_{SUP} = 5$ V, the register can be changed in steps of 4.9 mV.

Note If V_{OQ} is programmed to a negative voltage, the maximum signal voltage is limited to:

$$V_{Signal\ max} = V_{OQ} + V_{SUP}$$

Reference Level Register

The LOW-LEVEL and HIGH-LEVEL registers contain the reference values of the comparator.

The Low-Level is programmable between 0 V and $V_{SUP}/2$. The register can be changed in steps of 9.77 mV. The High-Level is programmable between 0 V and V_{SUP} in steps of 9.77 mV.

The four parameters Sensitivity, V_{OQ} , Low-Level, and High-Level define the switching points B_{ON} and B_{OFF} . For calibration in the system environment, a two-point adjustment procedure is recommended (see Section 3.3.). The suitable parameter set for each sensor can be calculated individually by this procedure.

GP Register

This register can be used to store information, like production date or customer serial number. TDK-Micronas will store production lot number, wafer number and x,y coordinates in registers GP1 to GP3. The total register contains four blocks (GP0 to GP3) with a length of 13 bits each. The customer can read out this information and store it in his production data base for reference or he can store own production information instead.

Note This register is not a guarantee for traceability because readout of registers is not possible after locking the IC.

To read/write this register it is mandatory to read/write all GP register one after the other starting with GP0. In case of a writing the registers it necessary to first write all registers followed by one store sequence at the end. Even if only GP0 should be changed all other GP registers must first be read and the read out data must be written again to these registers.

LOCK Register

By setting the LSB of this 2-bit register, all registers will be locked, and the sensor will no longer respond to any supply voltage modulation. This bit is active after the first power-off and power-on sequence after setting the Lock bit.

Warning This register cannot be reset!

ADC-READOUT Register

This 14-bit register delivers the actual digital value of the applied magnetic field after filtering but before the signal processing. This register can be read out and is the basis for the calibration procedure of the sensor in the system environment.

Digital Output

This 14-bit register delivers the actual value of the applied magnetic field after the signal processing.

This register can be read out and is the basis for the calibration procedure of the sensor in the system environment.

Note The MSB and LSB are reversed compared with all the other registers. Please reverse this register after readout.

Note During calibration it is mandatory to set the parameter for OUTPUT MODE to 0. The Digital Output register can be read out only in this configuration. For other configurations of the OUTPUT MODE the result read back from the sensor will be 0. After the calibration the output format can than easily be switched to the wanted output mode.

3.3. General Calibration Procedure

For calibration in the system environment, the application kit from TDK-Micronas is recommended. It contains the hardware for the generation of the serial telegram for programming and the corresponding software for the input or calculation of the register values.

In this section, the programming of the sensor using this tool is explained. Please refer to Section 6. on page 32 for information about programming without this tool.

For the individual calibration of each sensor in the customer's application, a two-point adjustment is recommended (see Fig. 3–8 for an example). When using the application kit, the calibration can be done in three steps:

Step 1: Input of the registers which need not be adjusted individually

The magnetic circuit, the magnetic material with its temperature characteristics, and the filter frequency, are given for this application.

Therefore, the values of the following registers should be identical for all sensors in the application.

- FILTER
(according to maximum signal frequency)
The 500 Hz range is recommended for highest accuracy.
- RANGE
(according to the maximum magnetic field at the sensor position)
- TC and TCSQ
(depends on the material of the magnet and the other temperature dependencies of the application)

Write the appropriate settings into the HAL 1002 registers.

Step 2: Initialize DSP

As the Digital Output register value depends on the setting of SENSITIVITY, VOQ and HIGH/LOW LEVEL, these registers have to be initialized with defined values first:

- $VOQ_{INITIAL} = 2048$
- $Sens_{INITIAL} =$ (see Table 3–7)
- Low Level = 0
- High Level = 511

Table 3–7: Values for $Sens_{INITIAL}$

3 dB filter frequency	Register value for $Sens_{INITIAL}$ (decimal)
80 Hz	950
500 Hz	614
1 kHz	657
2 kHz	1313

Note This step is done by TDK-Micronas' customer software automatically by clicking the Write and Store button.

Step 3: Calculation of the Sensor Parameters

Fig. 3–8 shows the typical characteristics for a contactless switch. There is a mechanical range where the sensor must be switched high and where the sensor must be switched low.

Set the system to the calibration point where the sensor output must be high, and click the button “Readout B_{OFF} ”. The result is the corresponding digital value.

Then, set the system to the calibration point where the sensor output must be low, click the button “Readout B_{ON} ” and get the second digital value.

Now, adjust the hysteresis to the desired value. The hysteresis is the difference between the switching points and suppresses oscillation of the output signal. With 100% hysteresis, the sensor will switch low and high exactly at the calibration points. A lower value will adjust the switching points closer together. Fig. 3–8 shows an example with 80% hysteresis.

By clicking the button “calibrate and store”, the software will calculate the corresponding parameters for Sensitivity, VOQ, Low-Level, High-Level and stores these values in the EEPROM.

This calibration must be done individually for each sensor.

The sensor is now calibrated for the customer application. However, the programming can be changed again if necessary.

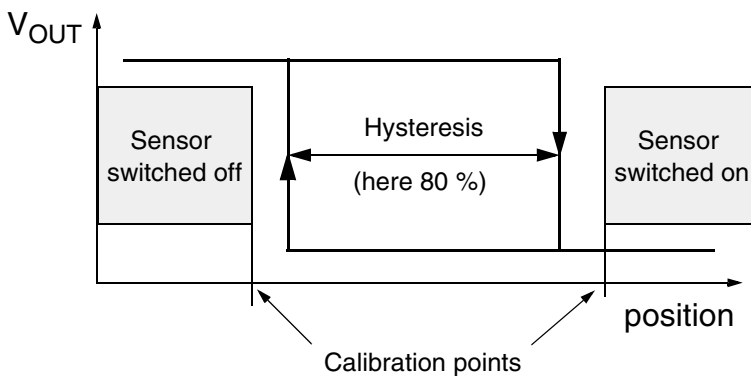

Fig. 3–8: Characteristics of a position switch

Step 4: Locking the Sensor

The last step is activating the Lock function with the “Lock” button. The sensor is now locked and does not respond to any programming or reading commands.

Warning The LOCK register cannot be reset!

3.4. Example: Calibration of a Position Switch

The following description explains the calibration procedure using a position switch as an example:

- The mechanical switching points are given
- Temperature coefficient of the magnet: -500 ppm/K

Step 1: Input of the registers which need not be adjusted individually

The register values for the following registers are given for all sensors in the application:

- FILTER Select the filter frequency: 500 Hz
- RANGE Select the magnetic-field range: 30 mT
- Output Mode Select the output mode: switch (positive polarity)
- TC For this magnetic material: 0
- TCSQ For this magnetic material: 0
- TC-Range For this magnetic material: -500 to 450 ppm/K

Enter these values in the software and use the “write and store” command to store these values permanently in the registers.

Step 2: Calculation of the sensor parameters

Set the system to the calibration point where the sensor output must be high and press “Readout B_{OFF}”.

Set the system to the calibration point where the sensor output must be low and press “Readout B_{ON}”.

Now, adjust the hysteresis to 80% and click the button “calibrate and store”.

Step 3: Locking the Sensor

The last step is activating the Lock function with the “Lock” command. The sensor is now locked and does not respond to any programming or reading commands. Please note that the Lock function becomes effective after power-down and power-up of the Hall-effect IC.

Warning The LOCK register cannot be reset!

4. Specifications

4.1. Outline Dimensions

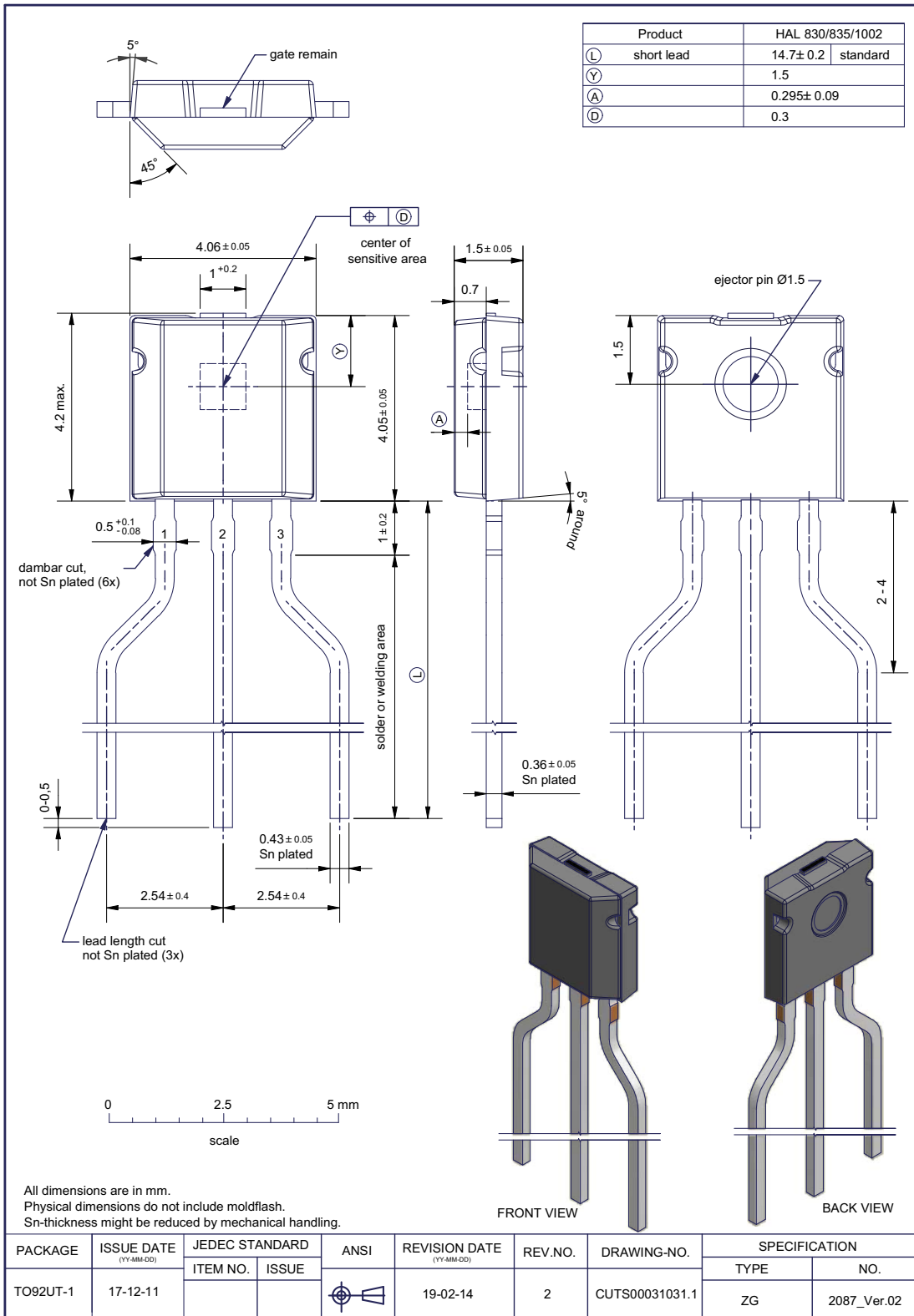
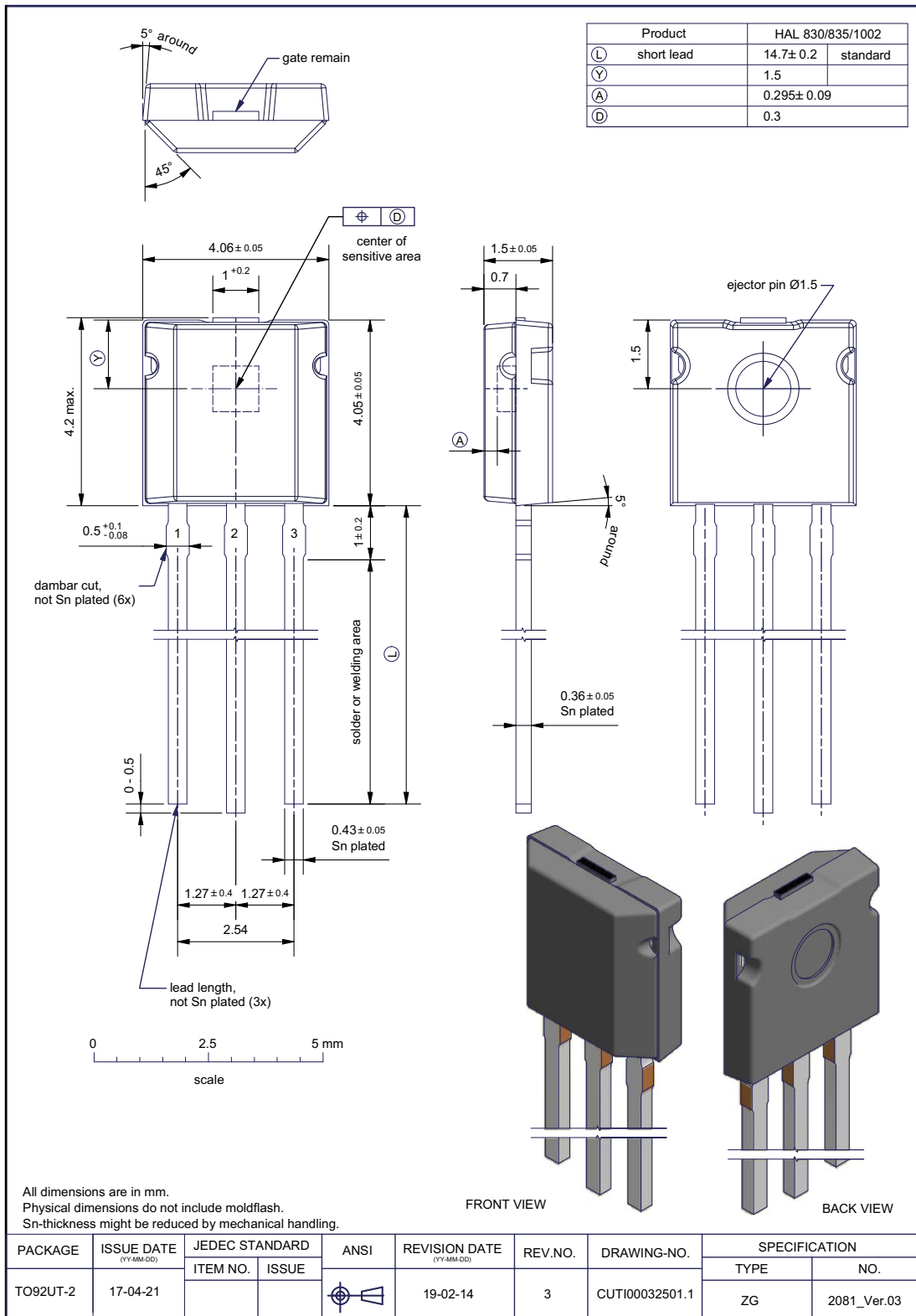

Fig. 4-1:
TO92UT-1 Plastic Transistor Standard UT package, 3 leads, non-spread
 Weight approximately 0.12 g



© Copyright 2017 TDK-Micronas GmbH, all rights reserved

Fig. 4-2:
TO92UT-2 Plastic Transistor Standard UT package, 3 leads, non-spread
 Weight approximately 0.12 g

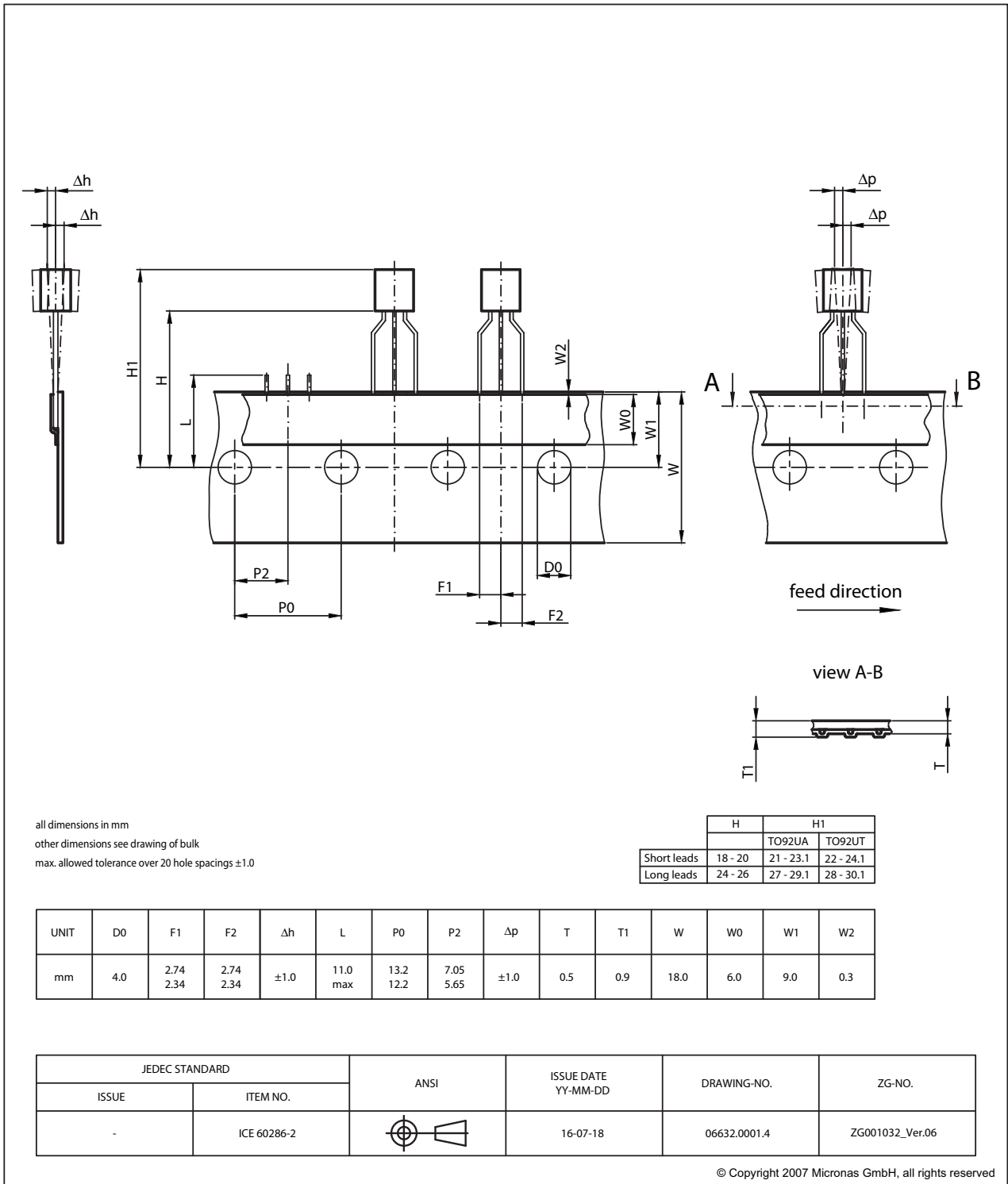

Fig. 4-3:
TO92UA/UT: Dimensions ammpack inline, spread

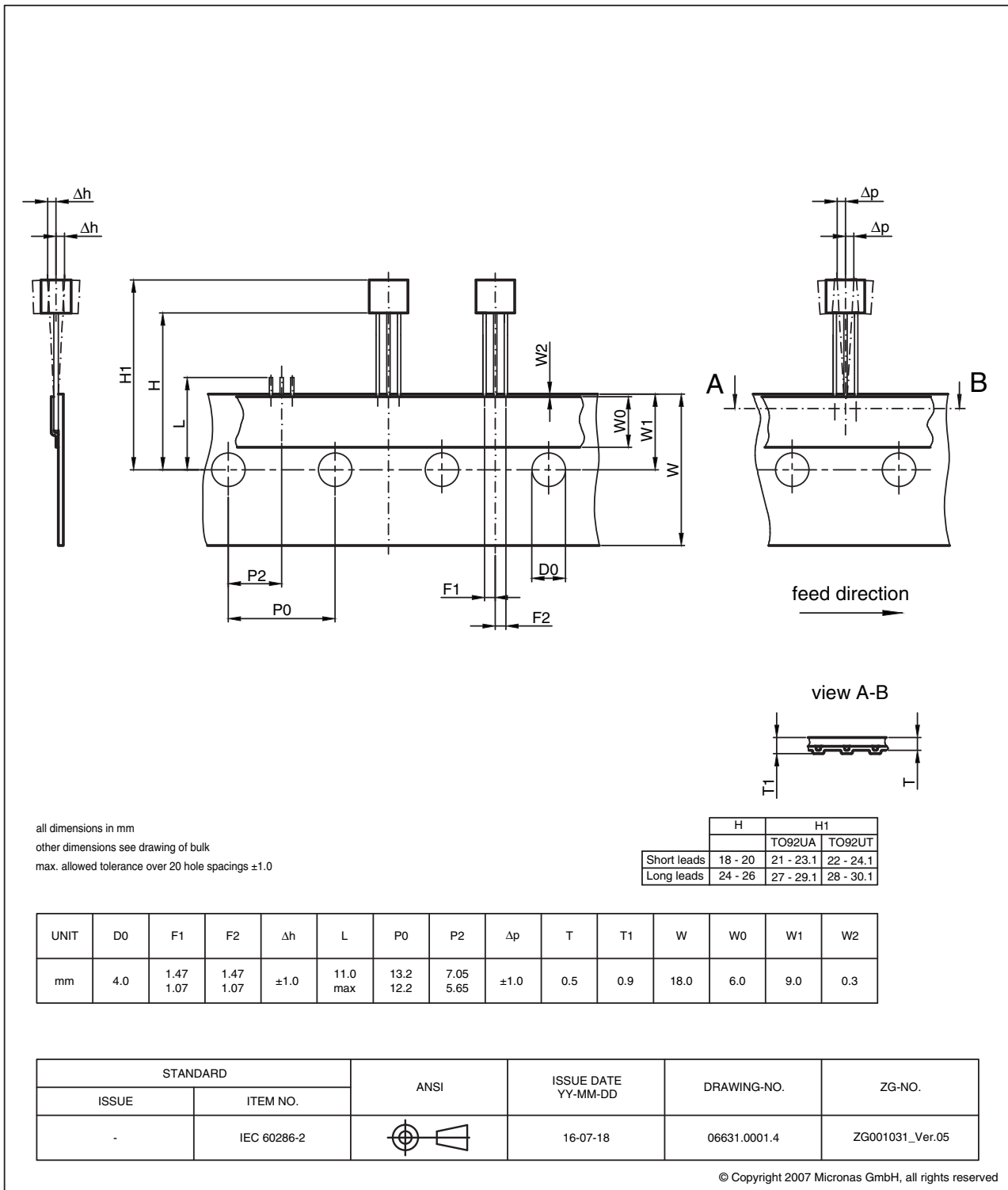

Fig. 4-4:
TO92UA/UT: Dimensions ammpack inline, not spread

4.2. Soldering, Welding and Assembly

Information related to solderability, welding, assembly, and second-level packaging is included in the document “Guidelines for the Assembly of Micronas Packages”.

It is available on the TDK-Micronas website (<http://www.micronas.com/en/service-center/downloads>) or on the service portal (<http://service.micronas.com>).

4.3. Pin Connections and Short Descriptions

Table 4–1: Pin connections and short descriptions

Pin No.	Pin Name	Short Description
1	VSUP	Supply voltage and programming pin
2	GND	Ground
3	OUT	Push-pull output and selection pin

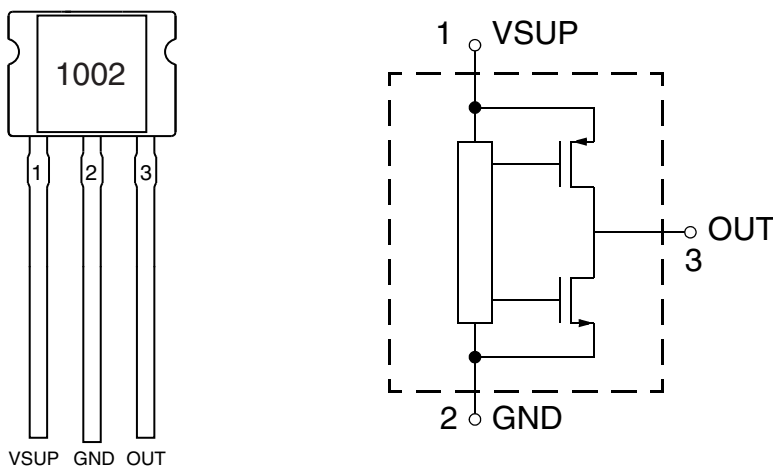

Fig. 4–5: Pin configuration

4.4. Dimension of Sensitive Area

Table 4–2: Dimension of sensitive area

Parameter	Min.	Typ.	Max.	Unit
Dimension of sensitive area	–	0.25 x 0.25	–	mm ²

4.5. Absolute Maximum Ratings

Stresses beyond those listed in the “Absolute Maximum Ratings” may cause permanent damage to the device. This is a stress rating only. Functional operation of the device at these conditions is not implied. Exposure to absolute maximum rating conditions for extended periods will affect device reliability.

This device contains circuitry to protect the inputs and outputs against damage due to high static voltages or electric fields; however, it is advised that normal precautions be taken to avoid application of any voltage higher than absolute maximum-rated voltages to this circuit.

All voltages listed are referenced to ground (GND).

Table 4–3: Absolute maximum ratings

Symbol	Parameter	Pin No.	Min.	Max.	Unit	Condition
V_{SUP}	Supply Voltage	1	–8.5	11	V	$t < 96 \text{ h}^{3)}$
V_{SUP}	Supply Voltage	1	–16	16	V	$t < 1 \text{ h}^{3)}$
V_{OUT}	Output Voltage	3	–5	16	V	
$V_{OUT} - V_{SUP}$	Excess of Output Voltage over Supply Voltage	3,1	–	2	V	
I_{OUT}	Continuous Output Current	3	–10	10	mA	
t_{Sh}	Output Short-Circuit Duration	3	–	10	min	
V_{ESD}	ESD Protection ¹⁾	1 3	–8.0 –7.5	8.0 7.5	kV	
T_J	Junction Temperature under Bias ²⁾		–50	190	°C	
$T_{STORAGE}$	Transportation/Short-Term Storage Temperature		–55	150	°C	Device only without packing material

¹⁾ AEC-Q100-002 (100 pF and 1.5 kΩ)

²⁾ For 96 h - Please contact TDK-Micronas for other temperature requirements

³⁾ No cumulated stress

4.6. Storage and Shelf Life

Information related to storage conditions of Micronas sensors is included in the document “Guidelines for the Assembly of Micronas Packages”. It gives recommendations linked to moisture sensitivity level and long-term storage.

It is available on the TDK-Micronas website (<http://www.micronas.com/en/service-center/downloads>) or on the service portal (<http://service.micronas.com>).

4.7. Recommended Operating Conditions

Functional operation of the device beyond those indicated in the “Recommended Operating Conditions/Characteristics” is not implied and may result in unpredictable behavior, reduce reliability and lifetime of the device.

All voltages listed are referenced to ground (GND).

Table 4–4: Recommended operating conditions

Symbol	Parameter	Pin No.	Min.	Typ.	Max.	Unit	Condition
V _{SUP}	Supply Voltage	1	4.5	5	8.5	V	
I _{OUT}	Continuous Output Current	3	–1.2	–	1.2	mA	
R _L	Load Resistor	3	5.0	–	–	kΩ	Can be pull-up or pull-down resistor
C _L	Load Capacitance	3	–	1	–	nF	
N _{PRG}	Number of EEPROM Programming Cycles	–	–	–	100	cycles	0°C < T _{AMB} < 55°C
T _J	Junction Temperature Range ¹⁾	–	–40 –40 –40	– – –	125 150 170	°C °C °C	for 8000 h ²⁾ for 2000 h ²⁾ for 1000 h ²⁾
¹⁾ Depends on the temperature profile of the application. Please contact TDK-Micronas for life time calculations. ²⁾ Time values are not cumulative							

4.8. Characteristics

at $T_J = -40\text{ °C}$ to 170 °C , $V_{SUP} = 4.5\text{ V}$ to 8.5 V , after programming and locking of the device, at Recommended Operation Conditions if not otherwise specified in the column "Conditions". Typical Characteristics for $T_J = 25\text{ °C}$ and $V_{SUP} = 5\text{ V}$.

Table 4–5: Characteristics

Symbol	Parameter	Pin No.	Min.	Typ.	Max.	Unit	Conditions
I_{SUP}	Supply Current over Temperature Range	1		7	10	mA	
V_{OUTH}	Output High Voltage	3	4.65	4.8		V	$V_{SUP} = 5\text{ V}$, $-1\text{ mA} \leq I_{OUT} \leq 1\text{ mA}$
V_{OUTL}	Output Low Voltage	3		0.2	0.35	V	$V_{SUP} = 5\text{ V}$, $-1\text{ mA} \leq I_{OUT} \leq 1\text{ mA}$
f_{ADC}	Internal ADC Frequency	–	120	128	140	kHz	$T_J = 25\text{ °C}$
f_{ADC}	Internal ADC Frequency over Temperature Range	–	110	128	150	kHz	$V_{SUP} = 5\text{ V}$
$t_{r(O)}$	Response Time of Output	3	–	5 4 2 1	10 8 4 2	ms ms ms ms	3 dB filter frequency = 80 Hz 3 dB filter frequency = 160 Hz 3 dB filter frequency = 500 Hz 3 dB filter frequency = 2 kHz $C_L = 10\text{ nF}$, time from 10% to 90% of final output voltage for a steplike signal B_{step} from 0 mT to B_{max}
$t_{d(O)}$	Delay Time of Output	3		0.1	0.5	ms	$C_L = 10\text{ nF}$
t_{POD}	Power-Up Time (Time to reach stabilized Output Voltage)			6 5 3 2	11 9 5 3	ms ms ms ms	3 dB filter frequency = 80 Hz 3 dB filter frequency = 160 Hz 3 dB filter frequency = 500 Hz 3 dB filter frequency = 2 kHz $C_L = 10\text{ nF}$, 90% of V_{OUT}
BW	Small Signal Bandwidth (–3 dB)	3	–	2	–	kHz	$B_{AC} < 10\text{ mT}$; 3 dB filter frequency = 2 kHz
R_{thja} R_{thjc} R_{thjs}	Thermal Resistance Junction to Ambient Junction to Case Junction to Solder Point	– – –	– – –	– – –	235 61 159	K/W K/W K/W	Determined with a 1s0p board Determined with a 1s0p board Determined with a 1s1p board
$B_{ON_OFF_res}$	Programming Resolution			12		bit	Including sign bit
$B_{ON_OFF_acc}$	Threshold Accuracy		–0.1		+0.1	%	At $T_J = 25\text{ °C}$ ¹⁾
$B_{ON_OFF_acc}$	Threshold Accuracy		–4		+4	%	Over operating temperature range ¹⁾
1) Characterized on small sample size, not tested.							

4.9. Magnetic Characteristics

at $T_J = -40\text{ °C}$ to 170 °C , $V_{SUP} = 4.5\text{ V}$ to 8.5 V , $GND = 0\text{ V}$ after programming and locking, at Recommended Operation Conditions if not otherwise specified in the column "Conditions". Typical Characteristics for $T_J = 25\text{ °C}$ and $V_{SUP} = 5\text{ V}$.

Table 4–6: Magnetic characteristics

Symbol	Parameter	Pin No.	Min.	Typ.	Max.	Unit	Test Conditions
B_{Offset}	Magnetic Offset	3	-0.5	0	0.5	mT	$B = 0\text{ mT}$, $I_{OUT} = 0\text{ mA}$, $T_J = 25\text{ °C}$, unadjusted sensor
ΔB_{Offset}	Magnetic Offset Drift		-200	0	200	μT	$B = 0\text{ mT}$, $I_{OUT} = 0\text{ mA}$ $V_{SUP} = 5\text{ V}$; 60 mT range, 3 dB frequency = 500 Hz, TC = 15, TCSQ = 1, TC range = 1 $-0.65 < \text{Sensitivity} < 0.65$

5. Application Notes

5.1. Application Circuit

For EMC protection, it is recommended to connect one ceramic 100 nF capacitor between ground and the supply voltage, and between ground and the output pin.

Please note that during programming, the sensor will be supplied repeatedly with the programming voltage of 12.5 V for 100 ms. All components connected to the V_{SUP} line at this time must be able to resist this voltage.

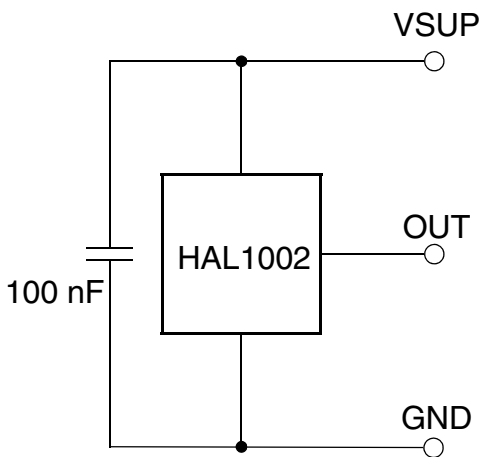

Fig. 5-1: Recommended application circuit

For application circuits for high supply voltages, such as 24 V, please contact TDK-Micronas' application service.

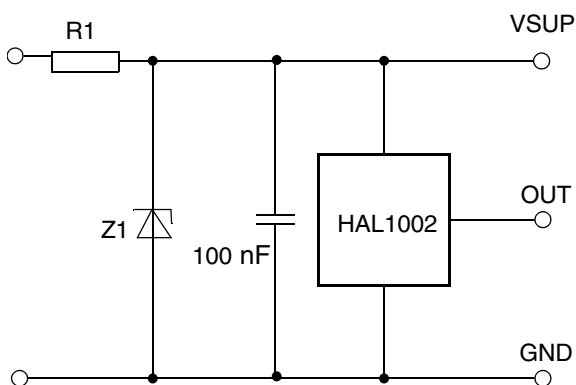

Fig. 5-2: Example for an application circuit for high supply voltage

5.2. Temperature Compensation

The relationship between the temperature coefficient of the magnet and the corresponding TC and TCSQ codes for linear compensation is given in the following table. In addition to the linear change of the magnetic field with temperature, the curvature can be adjusted as well. For this purpose, other TC and TCSQ combinations are required which are not shown in the table. Please contact TDK-Micronas for more detailed information on this higher order temperature compensation.

The HAL83x and HAL1002 contain the same temperature compensation circuits. If an optimal setting for the HAL83x is already available, the same settings may be used for the HAL1002.

Table 5–1: Temperature coefficients of magnet

Temperature Coefficient of Magnet (ppm/K)	TC-Range	TC	TCSQ
1075	3	31	7
1000	3	28	1
900	3	24	0
750	3	16	2
675	3	12	2
575	3	8	2
450	3	4	2
400	1	31	0
250	1	24	1
150	1	20	1
50	1	16	2
0	1	15	1
-100	1	12	0
-200	1	8	1
-300	1	4	4
-400	1	0	7
-500	1	0	0
-600	2	31	2
-700	2	28	1
-800	2	24	3
-900	2	20	6

Table 5–1: Temperature coefficients of magnet, continued

Temperature Coefficient of Magnet (ppm/K)	TC-Range	TC	TCSQ
-1000	2	16	7
-1100	2	16	2
-1200	2	12	5
-1300	2	12	0
-1400	2	8	3
-1500	2	4	7
-1600	2	4	1
-1700	2	0	6
-1800	0	31	6
-1900	0	28	7
-2000	0	28	2
-2100	0	24	6
-2200	0	24	1
-2400	0	20	0
-2500	0	16	5
-2600	0	14	5
-2800	0	12	1
-2900	0	8	6
-3000	0	8	3
-3100	0	4	7
-3300	0	4	1
-3500	0	0	4

Note

The table above shows only some approximate values. TDK-Micronas recommends to use the TC-Calc software to find optimal settings for temperature coefficients. Please contact TDK-Micronas for more detailed information.

5.3. Ambient Temperature

Due to the internal power dissipation, the temperature on the silicon chip (junction temperature T_J) is higher than the temperature outside the package (ambient temperature T_A).

$$T_J = T_A + \Delta T$$

At static conditions and continuous operation, the following equation applies:

$$\Delta T = I_{SUP} \times V_{SUP} \times R_{thJ}$$

For typical values, use the typical parameters. For worst case calculation, use the max. parameters for I_{SUP} and R_{th} , and the max. value for V_{SUP} from the application.

For $V_{SUP} = 5.5$ V, $R_{th} = 235$ K/W, and $I_{SUP} = 10$ mA, the temperature difference $\Delta T = 12.93$ K.

For all sensors, the junction temperature T_J is specified. The maximum ambient temperature T_{Amax} can be calculated as:

$$T_{Amax} = T_{Jmax} - \Delta T$$

5.4. EMC and ESD

Please contact TDK-Micronas for the detailed investigation reports with the EMC and ESD results.

6. Programming

6.1. Definition of Programming Pulses

The sensor is addressed by modulating a serial telegram on the supply voltage. The sensor answers with a serial telegram on the output pin.

The bits in the serial telegram have a different bit time for the V_{SUP} -line and the output. The bit time for the V_{SUP} -line is defined through the length of the Sync bit at the beginning of each telegram. The bit time for the output is defined through the Acknowledge bit.

A logical “0” is coded as no voltage change within the bit time. A logical “1” is coded as a voltage change between 50% and 80% of the bit time. After each bit, a voltage change occurs.

6.2. Definition of the Telegram

Each telegram starts with the Sync bit (logical 0), 3 bits for the Command (COM), the Command Parity bit (CP), 4 bits for the Address (ADR), and the Address Parity bit (AP).

There are 4 kinds of telegrams:

- Write a register (see Fig. 6–2)
After the AP bit, follow 14 Data bits (DAT) and the Data Parity bit (DP). If the telegram is valid and the command has been processed, the sensor answers with an Acknowledge bit (logical 0) on the output.
- Read a register (see Fig. 6–3)
After evaluating this command, the sensor answers with the Acknowledge bit, 14 Data bits, and the Data Parity bit on the output.
- Programming the EEPROM cells (see Fig. 6–4)
After evaluating this command, the sensor answers with the Acknowledge bit. After the delay time t_w , the supply voltage rises up to the programming voltage.
- Activate a sensor (see Fig. 6–5)
If more than one sensor is connected to the supply line, selection can be done by first deactivating all sensors. The output of all sensors have to be pulled to ground. With an activate pulse on the appropriate output pin, an individual sensor can be selected. All following commands will only be accepted from the activated sensor.

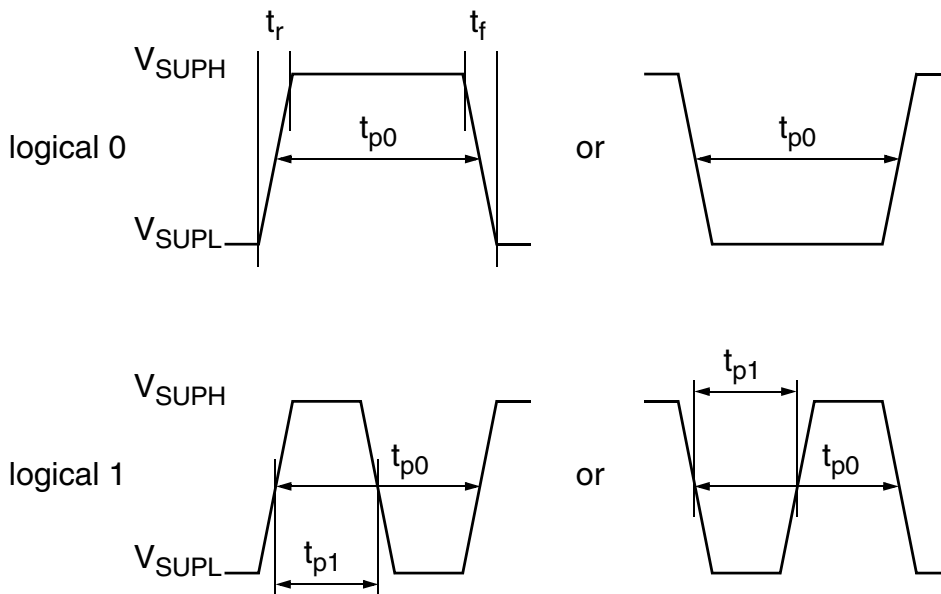

Fig. 6–1: Definition of logical 0 and 1 bit

Table 6–1: Telegram parameters

Symbol	Parameter	Pin	Min.	Typ.	Max.	Unit	Remarks
$V_{S_{UPL}}$	Supply voltage for Low-Level during programming	1	5	5.6	6	V	
$V_{S_{UPH}}$	Supply voltage for High-Level during programming	1	6.8	8.0	8.5	V	
t_r	Rise time	1	–	–	0.05	ms	
t_f	Fall time	1	–	–	0.05	ms	
t_{p0}	Bit time on $V_{S_{UP}}$	1	1.7	1.75	1.9	ms	t_{p0} is defined through the Sync bit
t_{pOUT}	Bit time on output pin	3	2	3	4	ms	t_{pOUT} is defined through the Acknowledge bit
t_{p1}	Duty-Cycle change for logical 1	1, 3	50	65	80	%	% of t_{p0} or t_{pOUT}
$V_{S_{UPPROG}}$	Supply voltage for programming the EEPROM	1	12.4	12.5	12.6	V	
t_{PROG}	Programming Time for EEPROM	1	95	100	105	ms	
t_{rp}	Rise time of programming voltage	1	0.2	0.5	1	ms	
t_{fp}	Fall time of programming voltage	1	0	–	1	ms	
t_w	Delay time of programming voltage after Acknowledge	1	0.5	0.7	1	ms	
V_{act}	Voltage for an activate pulse	3	3	4	5	V	
t_{act}	Duration of an activate pulse	3	0.05	0.1	0.2	ms	
$V_{out,deact}$	Output voltage after deactivate command	3	0	0.1	0.2	V	

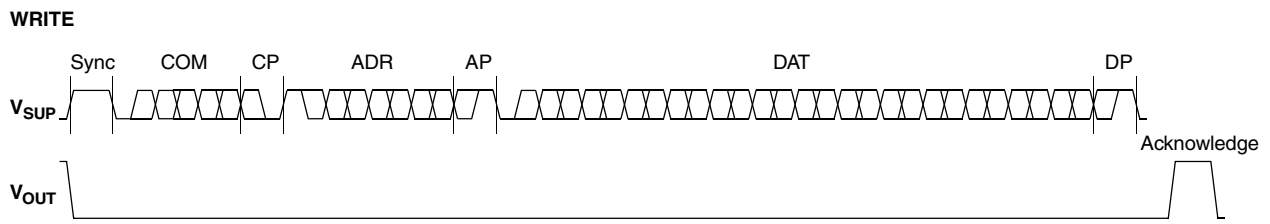

Fig. 6–2: Telegram for coding a Write command

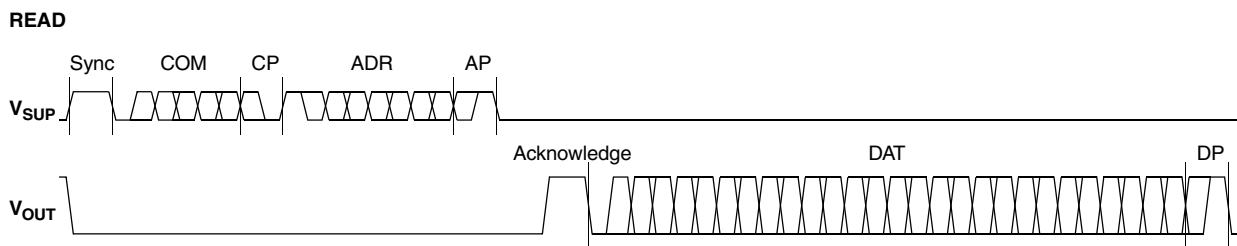

Fig. 6–3: Telegram for coding a Read command

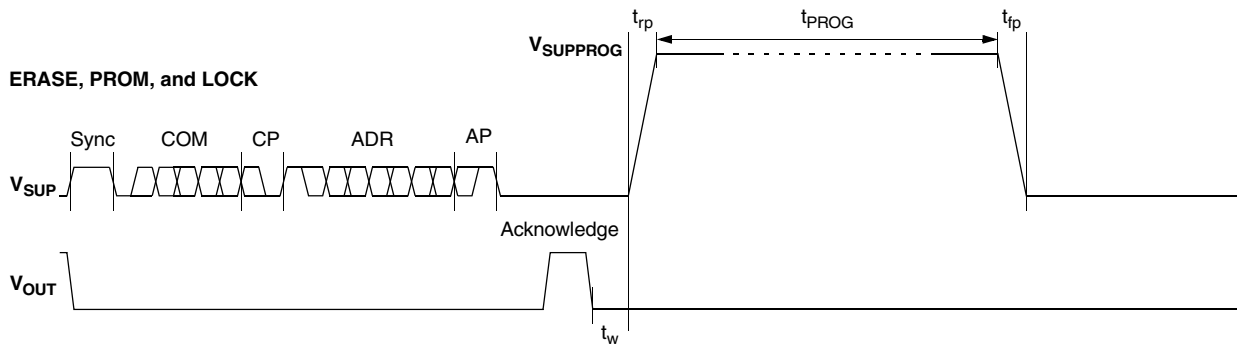

Fig. 6–4: Telegram for coding the EEPROM programming

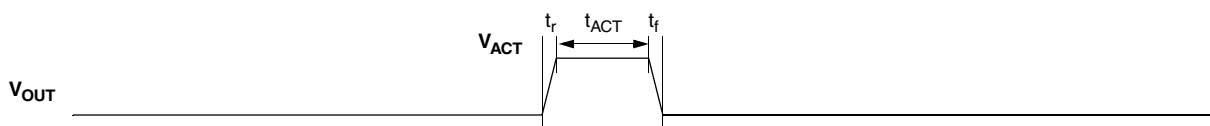

Fig. 6–5: Activate pulse

6.3. Telegram Codes

Sync Bit

Each telegram starts with the Sync bit. This logical “0” pulse defines the exact timing for t_{p0} .

Command Bits (COM)

The Command code contains 3 bits and is a binary number. Table 6–2 shows the available commands and the corresponding codes for the HAL 1002.

Command Parity Bit (CP)

This Command Parity bit is “1” if the number of zeros within the 3 Command bits is uneven. The Command Parity bit is “0”, if the number of zeros is even.

Address Bits (ADR)

The Address code contains 4 bits and is a binary number. Table 6–3 shows the available addresses for the HAL 1002 registers.

Address Parity Bit (AP)

This Address Parity bit is “1” if the number of zeros within the 4 Address bits is uneven. The Address Parity bit is “0” if the number of zeros is even.

Data Bits (DAT)

The 14 Data bits contain the register information.

The registers use different number formats for the Data bits. These formats are explained in Section 6.4.

In the Write command, the last bits are valid. If, for example, the TC register (10 bits) is written, only the last 10 bits are valid.

In the Read command, the first bits are valid. If, for example, the TC register (10 bits) is read, only the first 10 bits are valid.

Data Parity Bit (DP)

This Data Parity bit is “1” if the number of zeros within the binary number is even. The Data Parity bit is “0” if the number of zeros is uneven.

Acknowledge

After each telegram, the output answers with the Acknowledge signal. This logical “0” pulse defines the exact timing for t_{pOUT} .

Table 6–2: Available commands

Command	Code	Explanation
READ	2	Read a register
WRITE	3	Write a register
PROM	4	Program all nonvolatile registers (except the Lock bits)
ERASE	5	Erase all nonvolatile registers (except the Lock bits)

6.4. Number Formats

Binary Number:

The most significant bit is given as first, the least significant bit as last digit.

Example: 101001 represents 41 decimal.

Signed Binary Number:

The first digit represents the sign of the following binary number (1 for negative, 0 for positive sign).

Example: 0101001 represents +41 decimal
 1101001 represents –41 decimal

Two’s-Complement Number:

The first digit of positive numbers is “0”, the rest of the number is a binary number. Negative numbers start with “1”. In order to calculate the absolute value of the number, calculate the complement of the remaining digits and add “1”.

Example: 0101001 represents +41 decimal
 1010111 represents –41 decimal

6.5. Register Information

LOW LEVEL

- The register range is from 0 up to 255.
- The register value is calculated by:

$$\text{LOW LEVEL} = \frac{\text{Low-Level Voltage} \times 2}{V_{SUP}} \times 255$$

HIGH LEVEL

- The register range is from 0 up to 511.
- The register value is calculated by:

$$\text{HIGH LEVEL} = \frac{\text{High-Level Voltage}}{V_{SUP}} \times 511$$

VOQ

- The register range is from –1024 up to 1023.
- The register value is calculated by:

$$\text{VOQ} = \frac{V_{OQ}}{V_{SUP}} \times 1024$$

SENSITIVITY

- The register range is from –8192 up to 8191.
- The register value is calculated by:

$$\text{SENSITIVITY} = \text{Sensitivity} \times 2048$$

TC

- The TC register range is from 0 up to 1023.
- The register value is calculated by:

$$\text{TC} = \text{GROUP} \times 256 + \text{TCValue} \times 8 + \text{TCSQValue}$$

MODE

- The register range is from 0 up to 1023 and contains the settings for FILTER, RANGE, OUTPUTMODE and OFFSET CORRECTION:

$$MODE = RANGE \times 512 + SIGNOC \times 256 + OUTPUTMODE \times 32 + FILTER \times 8 + RANGE \times 2 + OFFSETCORRECTION$$

SIGNOC = Sign Offset Correction

D/A-READOUT

- This register is read only.
- The register range is from 0 up to 16383.

DEACTIVATE

- This register can only be written.
- The register has to be written with 2063 decimal (80F hexadecimal) for the deactivation.
- The sensor can be reset with an Activate pulse on the output pin or by switching off and on the supply voltage.

Table 6–3: Available register addresses

Register	Addr.	Data Bits	Format	Customer	Remark
LOW LEVEL	1	8	binary	read/write/program	Low voltage
HIGH LEVEL	2	9	binary	read/write/program	High voltage
VOQ	3	11	two's compl. binary	read/write/program	Output quiescent voltage
SENSITIVITY	4	14	signed binary	read/write/program	
MODE	5	10	binary	read/write/program	Range, filter, output mode
LOCKR	6	2	binary	read/write/program	Lock bit
A/D READOUT	7	14	two's compl. binary	read	
GP REGISTERS 1...3	8	3x13	binary	read/write/program	1)
DIGITAL-READOUT	9	14	binary	read	Bit sequence is reversed during read
TC	11	10	binary	read/write/program	Bits 0 to 2 TCSQ Bits 3 to 7 TC Bits 8 to 9 TC Range

Table 6–3: Available register addresses, continued

Register	Addr.	Data Bits	Format	Customer	Remark
GP REGISTER 0	12	13	binary	read/write/program	1)
DEACTIVATE	15	12	binary	write	Deactivate the sensor

1) To read/write this register it is mandatory to read/write all GP register one after the other starting with GP0. In case of a writing the registers it is necessary to first write all registers followed by one store sequence at the end. Even if only GP0 should be changed all other GP registers must first be read and the read out data must be written again to these registers.

Table 6–4: Data formats

Register	Char	DAT3				DAT2				DAT1				DAT0			
	Bit	15	14	13	12	11	10	09	08	07	06	05	04	03	02	01	00
LOW LEVEL	Write	–	–	–	–	–	–	–	–	V	V	V	V	V	V	V	V
	Read	–	–	V	V	V	V	V	V	V	V	–	–	–	–	–	–
HIGH LEVEL	Write	–	–	–	–	–	–	–	V	V	V	V	V	V	V	V	V
	Read	–	–	V	V	V	V	V	V	V	V	V	–	–	–	–	–
VOQ	Write	–	–	–	–	–	V	V	V	V	V	V	V	V	V	V	V
	Read	–	–	V	V	V	V	V	V	V	V	V	V	V	–	–	–
SENSITIVITY	Write	–	–	V	V	V	V	V	V	V	V	V	V	V	V	V	V
	Read	–	–	V	V	V	V	V	V	V	V	V	V	V	V	V	V
MODE	Write	–	–	–	–	–	–	V	V	V	V	V	V	V	V	V	V
	Read	–	–	V	V	V	V	V	V	V	V	V	V	–	–	–	–
LOCKR	Write	–	–	–	–	–	–	–	–	–	–	–	–	–	–	V	V
	Read	–	–	V	V	–	–	–	–	–	–	–	–	–	–	–	–
A/D-READOUT	Read	–	–	V	V	V	V	V	V	V	V	V	V	V	V	V	V
GP 1...3 Registers	Write	–	–	–	V	V	V	V	V	V	V	V	V	V	V	V	V
	Read	–	–	V	V	V	V	V	V	V	V	V	V	V	V	V	–
DIGITAL-READOUT ¹⁾	Read	–	–	V	V	V	V	V	V	V	V	V	V	V	V	V	V
TC	Write	–	–	–	–	–	–	V	V	V	V	V	V	V	V	V	V
	Read	–	–	V	V	V	V	V	V	V	V	V	V	–	–	–	–
GP 0 Register	Write	–	–	–	V	V	V	V	V	V	V	V	V	V	V	V	V
	Read	–	–	V	V	V	V	V	V	V	V	V	V	V	V	V	–
DEACTIVATE	Write	–	–	–	–	1	0	0	0	0	0	0	0	1	1	1	1

V: valid, –: ignore, bit order: MSB first
¹⁾ LSB first

6.6. Programming Information

If the content of any register (except the LOCK register) is to be changed, the desired value must first be written into the corresponding RAM register. Before reading out the RAM register again, the register value must be permanently stored in the EEPROM.

Permanently storing a value in the EEPROM is done by first sending an ERASE command followed by sending a PROM command. **The address within the ERASE and PROM commands must be zero.** ERASE and PROM act on all registers in parallel.

If all HAL 1002 registers are to be changed, all writing commands can be sent one after the other, followed by sending one ERASE and PROM command at the end.

During all communication sequences, the customer has to check if the communication with the sensor was successful. This means that the acknowledge and the parity bits sent by the sensor have to be checked by the customer. If the TDK-Micronas programmer board is used, the customer has to check the error flags sent from the programmer board.

Note For production and qualification tests it is mandatory to set the Lock bit after final adjustment and programming of HAL 1002. The Lock function is active after the next power-up of the sensor.
The success of the lock process shall be checked by reading at least one sensor register after locking and/or by an analog check of the sensors output signal.

Note Electrostatic discharges (ESD) may disturb the programming pulses. Please take precautions against ESD.

7. Document History

1. Preliminary Data Sheet “HAL 1002 Highly Precise Programmable Hall-Effect Switch”, Dec. 13, 2013, PD000214_001EN. First release of the preliminary data sheet.
2. Data Sheet “HAL 1002 Highly Precise Programmable Hall-Effect Switch”, April 25, 2014, DSH000163_001EN. First release of the data sheet.

Major Changes:

- Block diagram updated
- Parameter values for Programming Resolution and Threshold Accuracy added

3. Data Sheet “HAL 1002 Highly Precise Programmable Hall-Effect Switch”, Jan. 7, 2019, DSH000163_002EN. Second release of the data sheet.

Major Changes:

- EPROM registers and digital signal processing (Fig. 3–3) updated
- Note for digital signal processing and EEPROM added in Section 3.2.
- Offset Correction in Section 3.3. removed
- Table 3–2 (Magnetic range bits) updated
- Table 3–5 (TC-Register) added
- Table 3–6 (TC range) updated
- “Step 2: Initialize DSP” in Section 3.3. added
- Note for reading the DAC register added in Section 3.3.
- “Step 1: Input of the registers which need not be adjusted individually” in Section 3.4. updated
- Package and taping drawings updated
- Fig. 4–3 (Pin configuration) updated
- Storage temperature added
- Conditions of Rth values (Table 4–5) updated
- ADC register in Table 6–3 and Table 6–4 added and both tables updated

4. Data Sheet: “HAL 1002 Highly Precise Programmable Hall-Effect Switch”, Sept. 3, 2019, DSH000163_003EN. Third release of the data sheet.

Major Changes:

- Disclaimer updated
- TO92UT-1 (spread) added
- Package drawings updated
- Characteristic's parameter 'Threshold Accuracy' updated