

Data Sheet

HAL[®] 283x

Linear Hall-Effect Sensor Family
with SENT Interface

vario | HAL[®]
by Micronas

Copyright, Warranty, and Limitation of Liability

The information and data contained in this document are believed to be accurate and reliable. The software and proprietary information contained therein may be protected by copyright, patent, trademark and/or other intellectual property rights of Micronas. All rights not expressly granted remain reserved by Micronas.

Micronas assumes no liability for errors and gives no warranty representation or guarantee regarding the suitability of its products for any particular purpose due to these specifications.

By this publication, Micronas does not assume responsibility for patent infringements or other rights of third parties which may result from its use. Commercial conditions, product availability and delivery are exclusively subject to the respective order confirmation.

Any information and data which may be provided in the document can and do vary in different applications, and actual performance may vary over time.

All operating parameters must be validated for each customer application by customers' technical experts. Any new issue of this document invalidates previous issues.

Micronas reserves the right to review this document and to make changes to the document's content at any time without obligation to notify any person or entity of such revision or changes. For further advice please contact us directly.

Do not use our products in life-supporting systems, military, aviation, or aerospace applications! Unless explicitly agreed to otherwise in writing between the parties, Micronas' products are not designed, intended or authorized for use as components in systems intended for surgical implants into the body, or other applications intended to support or sustain life, or for any other application in which the failure of the product could create a situation where personal injury or death could occur.

No part of this publication may be reproduced, photocopied, stored on a retrieval system or transmitted without the express written consent of Micronas.

Micronas Trademarks

- HAL
- varioHAL

Third-Party Trademarks

All other brand and product names or company names may be trademarks of their respective companies.

Contents, continued

Page	Section	Title
4	1.	Introduction
4	1.1.	Features
4	1.2.	Major Applications
5	2.	Ordering Information
5	2.1.	Device-Specific Ordering Codes
6	3.	Functional Description
6	3.1.	General Function
7	3.2.	Digital Signal Processing
8	3.2.1.	Temperature Compensation
9	3.2.2.	DSP Configuration Registers
12	3.3.	Power-on Self Test (POST)
13	3.3.1.	Description of POST Implementation
13	3.3.2.	RAM Test
13	3.3.3.	ROM Test
13	3.3.4.	EEPROM Test
13	3.4.	Sensor Behavior in Case of External Errors
13	3.5.	Detection of Signal Path Errors
14	4.	Specifications
14	4.1.	Outline Dimensions
18	4.2.	Soldering, Welding and Assembly
18	4.3.	Pin Connections and Short Descriptions
18	4.4.	Dimensions of Sensitive Area
18	4.5.	Positions of Sensitive Area
19	4.6.	Absolute Maximum Ratings
19	4.6.1.	Storage and Shelf Life
20	4.7.	Recommended Operating Conditions
20	4.8.	Characteristics
22	4.9.	Magnetic Characteristics
23	4.9.1.	Definition of Sensitivity Error ES
24	5.	The SENT Module
24	5.1.	Serial data messages (short format)
26	5.2.	SENT Message Timing
27	5.2.1.	HAL2830/HAL2831 message timing (no pause period)
28	5.2.2.	HAL 2832/HAL2833 message timing (with pause period)
30	6.	Programming of the Sensor
30	6.1.	Programming Interface
31	6.2.	Programming Environment and Tools
31	6.3.	Programming Information
32	7.	Application Notes
32	7.1.	Ambient Temperature
32	7.2.	EMC and ESD
32	7.3.	Application Circuit
34	8.	Data Sheet History

Linear Hall-Effect Sensor Family with SENT Interface

Release Note: Revision bars indicate significant changes to the Advance Information.

1. Introduction

HAL 283x is a Micronas family of programmable linear Hall-effect sensors with SENT output. The family consists of the four members described in Table 1–1:

Table 1–1: Family Overview

Type	Resolution	Pause Period	SENT version
HAL2830	12 bit	No	SAE-J2716 release 2010-01
HAL2831	16 bit	No	SAE-J2716 release 2010-01
HAL 2832	12 bit	Yes	SAE-J2716 release 2010-01
HAL2833	16 bit	Yes	SAE-J2716 release 2010-01

HAL 283x features a temperature-compensated Hall plate with spinning-current offset compensation, an A/D converter, digital signal processing, an EEPROM memory with redundancy and lock function for the calibration data, and protection devices at all pins. The internal digital signal processing is of great benefit because analog offsets, temperature shifts, and mechanical stress do not degrade digital signals.

The easy programmability allows a 2-point calibration by adjusting the output signal directly to the input signal (like mechanical angle, distance, or current). Individual adjustment of each sensor during the customer’s manufacturing process is possible. With this calibration procedure, the tolerances of the sensor, the magnet, and the mechanical positioning can be compensated in the final assembly.

In addition, the temperature-compensation of the Hall IC can be fit to all common magnetic materials by programming first- and second-order temperature coefficients of the Hall sensor sensitivity. It is also possible to compensate offset drifts over temperature generated by the customer application with a first-order temperature coefficient of the sensor offset. This enables operation over the full temperature range with high accuracy.

For programming purposes, the sensor features a programming interface with a Biphase-M protocol on the DIO pin (output).

In the application mode, the sensor provides a continuous SENT data stream.

1.1. Features

- High-precision linear Hall-effect sensor
- Spinning current offset compensation
- 20 bit digital signal processing
- Output resolution up to 16 bit
- Magnetic measurement range over temperature adjustable from ±24 mT up to ±96 mT
- Sample period programmable from 0.5 ms to 33 ms
- Various sensor parameter are programmable: offset, sensitivity, temperature compensation for sensitivity (2nd order) and offset (1st order), etc.
- Programming and operation of multiple sensors at the same supply line
- Biphase-M interface (programming mode)
- Non-volatile memory with lock function
- SENT clock tick time programmable between 2 µs and 17.75 µs
- Pulse low time programmable between 3 and 6.75 clock ticks
- Sample accurate transmission of magnetic field information
- Transmission of temperature and device information by serial data messages in the status nibble
- Open-drain output with slew rate control (load independent)
- On-board diagnostics (overvoltage, output current, overtemperature, signal path overflow)
- Power-on self-test covering all memories and full signal path from Hall plates to SENT output
- ESD protection at DIO pin
- Reverse voltage and ESD protection at VSUP pin
- High immunity against mechanical stress, ESD, and EMC
- AECQ-100 rev. G qualified

1.2. Major Applications

- Steering torque
- Suspension level
- Throttle position
- Pedal position
- Valve position

2. Ordering Information

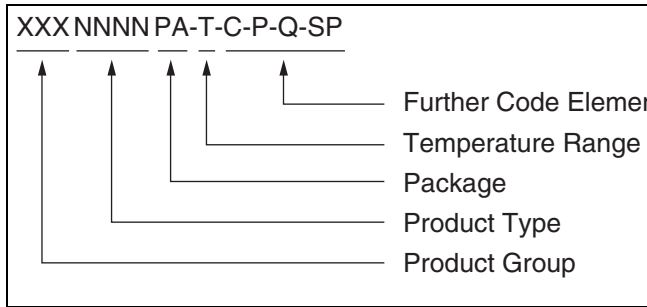

Fig. 2-1: Ordering Code Principle

For a detailed information, please refer to the brochure: "Micronas Sensors and Controllers: Ordering Codes, Packaging, Handling".

2.1. Device-Specific Ordering Codes

HAL 283x is available in the following package and temperature variants.

Table 2-1: Available package

Package Code (PA)	Package Type
UT	TO92UT

Table 2-2: Available temperature range

Temperature Code (T)	Temperature Range
A	$T_J = -40\text{ °C to }+170\text{ °C}$

The relationship between ambient temperature (T_A) and junction temperature (T_J) is explained in Section 5.4. on page 29.

For available variants for Configuration (C), Packaging (P), Quantity (Q), and Special Procedure (SP) please contact Micronas.

Table 2-3: Available ordering codes and corresponding package marking

Available Ordering Codes	Package Marking
HAL2830-A-[C-P-Q-SP]	2830A
HAL2831-A-[C-P-Q-SP]	2831A
HAL2832-A-[C-P-Q-SP]	2832A
HAL2833-A-[C-P-Q-SP]	2833A

3. Functional Description

3.1. General Function

The HAL 283x is a monolithic integrated circuit, which provides an output signal proportional to the magnetic flux through the Hall plate.

The external magnetic field component, perpendicular to the branded side of the package, generates a Hall voltage. The Hall IC is sensitive to magnetic north and south polarity. This voltage is converted to a digital value, processed in the digital signal processing Unit (DSP) according to the settings of the EEPROM registers.

The function and the parameters for the DSP are explained in Section 3.2. on page 7.

Internal temperature compensation circuitry and the spinning current offset compensation enables operation over the full temperature range with minimal changes in accuracy and high offset stability. The circuitry also rejects offset shifts due to mechanical stress from the package.

The HAL 283x provides two operation modes, the application mode and the programming mode.

Application Mode

The output signal is provided as continuous SENT data stream.

Programming Mode

For the programming of the sensor parameters, a Biphase-M protocol is used.

The HAL 283x provides non-volatile memory which is divided in different blocks. The first block is used for the configuration of the digital signal processing, the second one is used by the various customer settings. The non-volatile memory employs inherent redundancy.

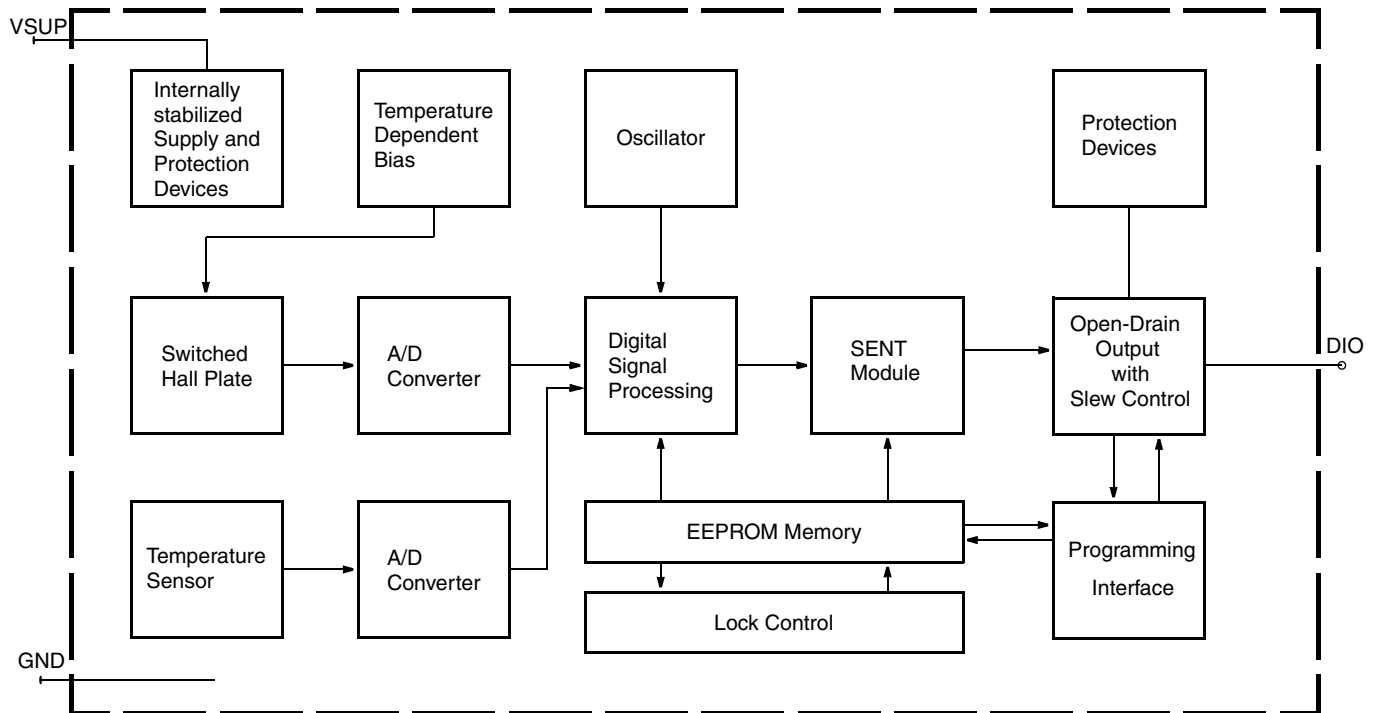

Fig. 3-1: HAL 283x block diagram

3.2. Digital Signal Processing

All parameters and the values y , y_{TCI} are normalized to the interval $(-1, 1)$ which represents the full scale magnetic range as programmed in the RANGE register.

Example for 40 mT Range

-1 equals -40 mT
+1 equals +40 mT

For the definition of the register values, please refer to Section 3.2.2. on page 9

The digital signal processing (DSP) is the major part of the sensor and performs the signal conditioning. The parameters of the DSP are stored in the DSP CONFIG area of the EEPROM.

The device provides a digital temperature compensation. It consists of the internal temperature compensation, the customer temperature compensation, as well as an offset and sensitivity adjustment. The internal temperature compensation (factory compensation) eliminates the temperature drift of the Hall sensor itself. The customer temperature compensation is calculated after the internal temperature drift has been compensated. Thus, the customer has not to take care about the sensor's internal temperature drift.

The output value y is calculated out of the factory-compensated Hall value y_{TCI} as:

$$y = [y_{TCI} + d(TVAL)] \cdot c(TVAL)$$

Parameter d is representing the offset and c is the coefficient for sensitivity.

The signal path contains a digital low-pass filter up to second order with a programmable sampling frequency from 32 Hz up to 2 kHz (see Table 3-2 on page 11).

The current Hall value y is stored in the data register HVD immediately after it has been temperature compensated.

A new SENT message transmits the recent temperature compensated Hall sample HVAL stored in the HVD register.

After power-up, HVAL and TVAL, respectively stored in the registers HVD and TVD, are set to the negative overflow value until valid data are available.

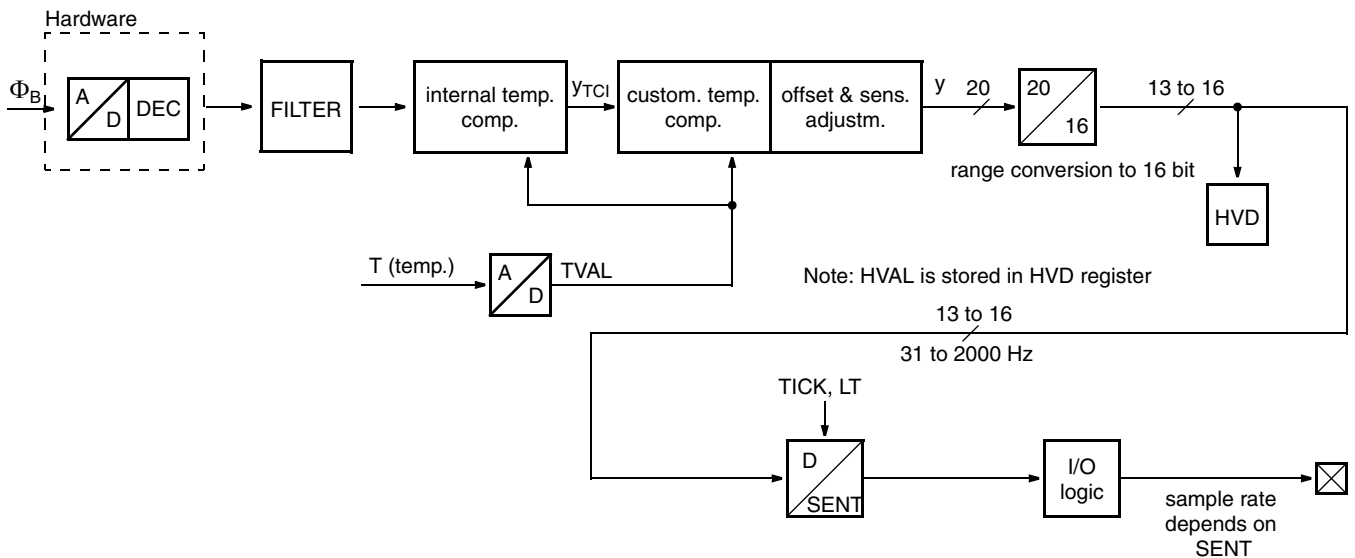

Fig. 3-2: Block diagram of digital signal path including digital filter.

3.2.1. Temperature Compensation

Terminology:

D0: name of the register or register value

d₀: name of the parameter

The customer programmable parameters “c” (sensitivity) and d (offset) are polynomials of the temperature. The temperature is represented by the adjusted read-out value TVAL of a built-in temperature sensor.

The update rate of the temperature value TVAL is less than 100 ms.

The sensitivity polynomial c(TVAL) is of second order in temperature:

$$c(TVAL) = c_0 + c_1 \cdot TVAL + c_2 \cdot TVAL^2$$

For the definition of the polynomial coefficients please refer to Section 3.2.2. on page 9.

The Offset polynomial d(T_{ADJ}) is linear in temperature:

$$d(TVAL) = d_0 + d_1 \cdot TVAL$$

For the definition of the polynomial coefficients, please refer to Section 3.2.2. on page 9.

For the calibration procedure of the sensor in the system environment, the two values HVAL and TADJ are provided. These values are stored in volatile registers.

HVAL

The number HVAL represents the digital output value y which is proportional to the applied magnetic field.

HVAL is a 16-bit two’s complement binary ranging from –32768 to +32767.

It is stored in the HVD register.

$$y = \frac{HVAL}{32768}$$

In case of internal overflows, the output will clamp to the maximum or minimum HVAL value.

Please take care that during calibration, the output signal range does not reach the maximum/minimum value.

TVAL

The number TVAL provides the adjusted value of the built-in temperature sensor.

TVAL is a 16-bit two’s complement binary ranging from –32768 to 32767.

It is stored in the TVD register.

Note: The actual resolution of the temperature sensor is 12 bit. The 16-bit representation avoids rounding errors in the computation.

The relation between TVAL and the junction temperature T_J is

$$T_J = \alpha_0 + TVAL \cdot \alpha_1$$

Table 3–1: Relation between T_J and T_{ADJ} (typical values)

Coefficient	Value	Unit
α ₀	71.65	°C
α ₁	1 / 231.56	°C

3.2.2. DSP Configuration Registers

This section describes the function of the DSP configuration registers. For details on the EEPROM, registers and memory mapping please refer to the Application Note "HAL 283x Programming Guide".

Magnetic Range: RANGE

The RANGE register defines the magnetic range of the A/D converter. The RANGE register has to be set according to the applied magnetic field range.

EEPROM. RANGE	Nominal Range	Usable range over temperature ⁽¹⁾
0	reserved	-
1	±40 mT	±24 mT
2	±60 mT	±36 mT
3	±80 mT	±48 mT
4	±100 mT	±60 mT
5	±120 mT	±72 mT
6	±140 mT	±84 mT
7	±160 mT	±96 mT
⁽¹⁾ Values of magnetic range over temperature are defined according to the parameter RANGE _{abs} listed in Section 4.9. on page 22. The minimum value has to be used in order to guarantee no clipping over temperature		

Filter Settings: FS and resolution of HVAL

The FS register defines the sampling frequency of the built in digital low-pass filter (see Table 3-2 on page 11).

Fig. 3-3 shows the magnitude of the transfer function for all recommended settings of FS at the pass band and stop band. Fig. 3-4 is a zoom-in of the magnitude at the pass band.

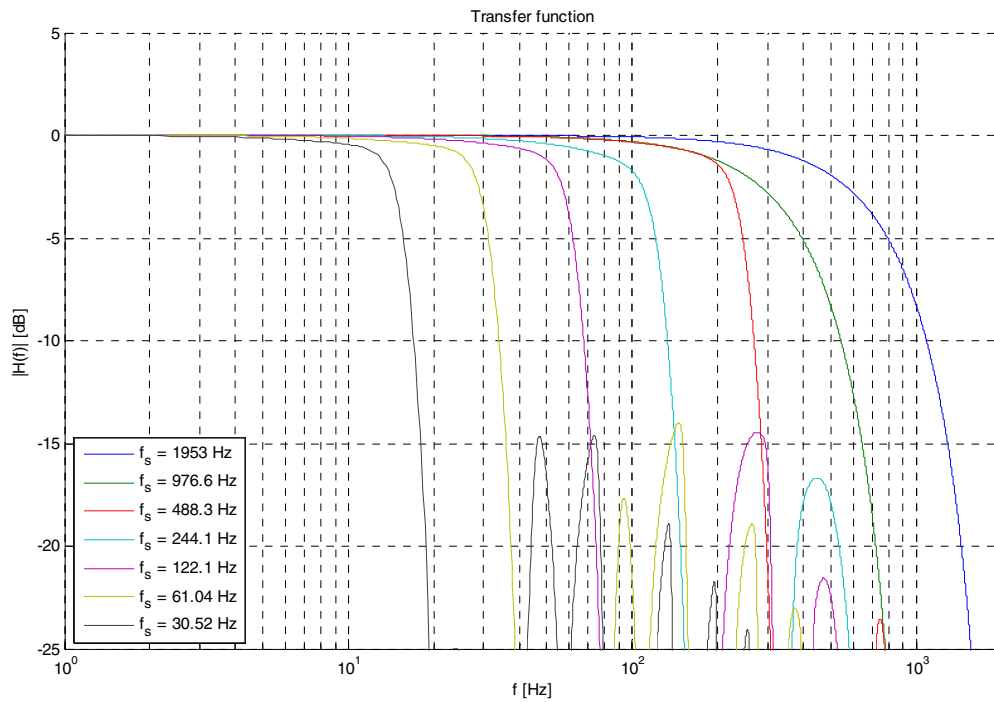

Fig. 3-3: Transfer function, magnitude

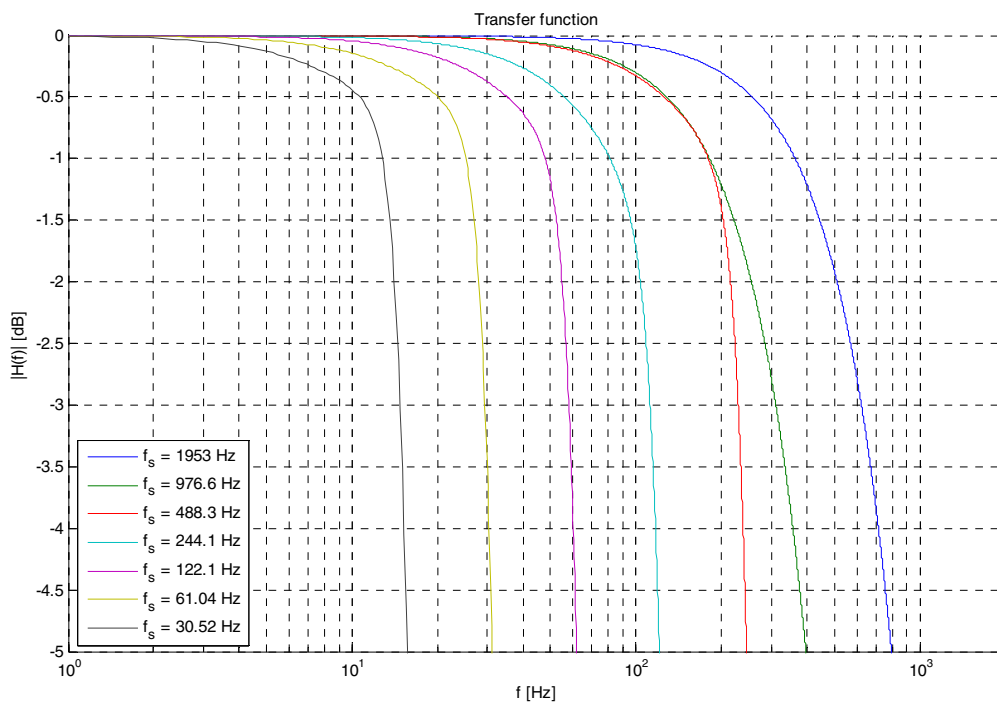

Fig. 3-4: Transfer function, magnitude - zoom-in at the pass band.

Table 3–2: Available sample frequencies, low pass filter settings and corresponding HVAL resolution.

Sample Frequency		FS	Resolution of HVAL ¹⁾	
Typ.			HAL 2831/3	HAL 2830/2
[Hz]	[ms]	[Hex]	[LSB]	[LSB]
2000	0.5	0x00	13	12
1000	1	0x01	15	12
500	2	0x03	16	12
250	4	0x07		
125	8	0x0B		
62	16	0x0F		
31	32	0x13		

¹⁾ HVAL is MSB aligned.

Magnetic Offset D

The D (offset) registers contain the parameters for the adder in the DSP. The added value is a first order polynomial of the temperature.

D0 Register

Table 3–3: Temperature independent coefficient

Parameter	Range	Resolution
d ₀	-0.5508 ... 0.5497	10 bit
D0	-512 ... 511	

D0 is encoded as two's complement binary.

$$d_0 = \frac{0.5508}{512} \cdot D0$$

D1 Register

Table 3–4: Linear temperature coefficient

Parameter	Range	Resolution
d ₁	-3.076 x 10 ⁻⁶ ... 3.028 x 10 ⁻⁶	7 bit
D1	-64 ... 63	

D1 is encoded as two's complement binary.

$$d_1 = \frac{0.1008}{64} \cdot D1 \cdot 3.0518 \cdot 10^{-5}$$

Magnetic Sensitivity C

The C (sensitivity) registers contain the parameters for the multiplier in the DSP. The multiplication factor is a second order polynomial of the temperature.

C0 Register

Table 3–5: Temperature independent coefficient

Parameter	Range	Resolution
c ₀	-2.0810 ... 2.2696	12 bit
C0	-2048 ... 2047	

C0 is encoded as two's complement binary:

$$c_0 = \frac{2.1758}{2048} \cdot (C0 + 89.261)$$

C1 Register

Table 3–6: Linear temperature coefficient

Parameter	Range	Resolution
c ₁	-7.955 x 10 ⁻⁶ ... 1.951 x 10 ⁻⁵	9 bit
C1	-256 ... 255	

C1 is encoded as two's complement binary.

$$c_1 = \frac{0.4509}{256} \cdot (C1 + 108.0) \cdot 3.0518 \cdot 10^{-5}$$

C2 Register

Table 3–7: Quadratic temperature coefficient

Parameter	Range	Resolution
c ₂	-1.87 x 10 ⁻¹⁰ ... 1.86 x 10 ⁻¹⁰	8 bit
C2	-128 ... 127	

C2 is encoded as two's complement binary.

$$c_2 = \frac{0.2008}{128} \cdot C2 \cdot 9.3132 \cdot 10^{-10}$$

3.3. Power-on Self Test (POST)

The HAL 283x features a built-in power-on self test to support in system start-up test to enhanced the system failure detection possibilities.

The power-on self test comprises the following sensor blocks:

- RAM
- ROM
- EEPROM
- Full signal path included (Hall-Plates, ADC, low pass filter, temperature compensation and the SENT output)

The power-on self test can be activated by setting certain bits in the sensor's EEPROM. Also the test complexity is customer selectable. The following table shows the available test combinations.

Table 3–8: Power-On Self Test Modes

EEPROM.POST			Mode / Function
[2]	[1]	[0]	
x	x	0	POST disabled.
x	0	1	Memory test enabled (RAM, ROM, EEPROM).
x	1	1	Memory test and signal path stimulation enabled.
0	x	1	POST errors will be reported at the register PTE and transmitted by the serial data channel of the SENT interface. In case of failed POST, the SENT interface transmits Hall values after the POST. This hall values might not be reliable.
1	x	1	POST errors will be reported at the status register PTE and transmitted by the serial data channel of the SENT interface. In case of failed POST, the HVAL is set to -32768 (underflow value) and the SENT interface transmits the underflow value after the POST.

3.3.1. Description of POST Implementation

HAL 283x starts the internal POST as soon as the external supply voltage reaches the minimum supply voltage (V_{SUPon}). The sensor output is disabled during the memory test. It is enabled after the memory test has been finished.

3.3.2. RAM Test

The RAM test consists of an address test and a RAM cell test. The address test checks if each byte of the RAM can be singly accessed. The RAM cell test checks if the RAM cells are capable of holding both 0 and 1.

3.3.3. ROM Test

The ROM test consists of a checksum algorithm. The checksum is calculated by a byte by byte summation of the entire ROM. The 8-bit checksum value is stored in the ROM.

The checksum is calculated at the ROM test using the entire ROM and is then compared with the stored checksum. An error will be indicated in case that there is a difference between stored and calculated checksum.

3.3.4. EEPROM Test

The EEPROM test is similar to the ROM test. The only difference is that the checksum is calculated for the EEPROM memory and that the 8-bit checksum is stored in one register of the EEPROM.

3.4. Sensor Behavior in Case of External Errors

HAL 283x shows the following behavior in case of external errors:

- Short of output against VSUP: The output is thermal protected and the current limited by the output driver strength (see V_{OL} in Section 4.8.). Due to the SENT message characteristic of short low pulses and a large high to low level ratio, the mean energy in case of a short output to Vsup is low.
- Break of VsUP or GND line: A sensor with open-drain output and digital interface does not need a wire-break detection logic. The wire-break function is covered by the pull-up resistor on the receiver. An output always high indicates a GND or VsUP line break. This error can be detected right at its occurrence.
- Under or over voltage: The sensor output is switched off (high impedance) after under or over voltage has been detected by the sensor.
- Over temperature detection: The sensor output is switched off (high impedance) after a too high temperature has been detected by the sensor (typ. 180°C). It is switched on again after the chip temperature has reached a normal level. A build in hysteresis avoids oscillation of the output (typ. 25°C)

3.5. Detection of Signal Path Errors

HAL 283x can detect the following overflows within the signal path:

- A positive overflow of the A/D converter, a positive overflow within the calculation of the low pass filter or the temperature compensation will set the hall value HVAL to +32767
- A negative overflow of the ADC or a negative overflow within the calculation of the low pass filter or the temperature compensation will set the hall value HVAL to -32768
- A positive or negative overflow of the A/D converter of the temperature sensor or a positive or negative overflow within the calculation of the calibrated temperature value TVAL will set the temperature value TVAL to -32768 or +32767, and the hall value HVAL to -32768

Signal processing errors are recorded at the SPE status register and transmitted by the serial data channel of the SENT interface (see register definition in Section 5.1.).

4. Specifications

4.1. Outline Dimensions

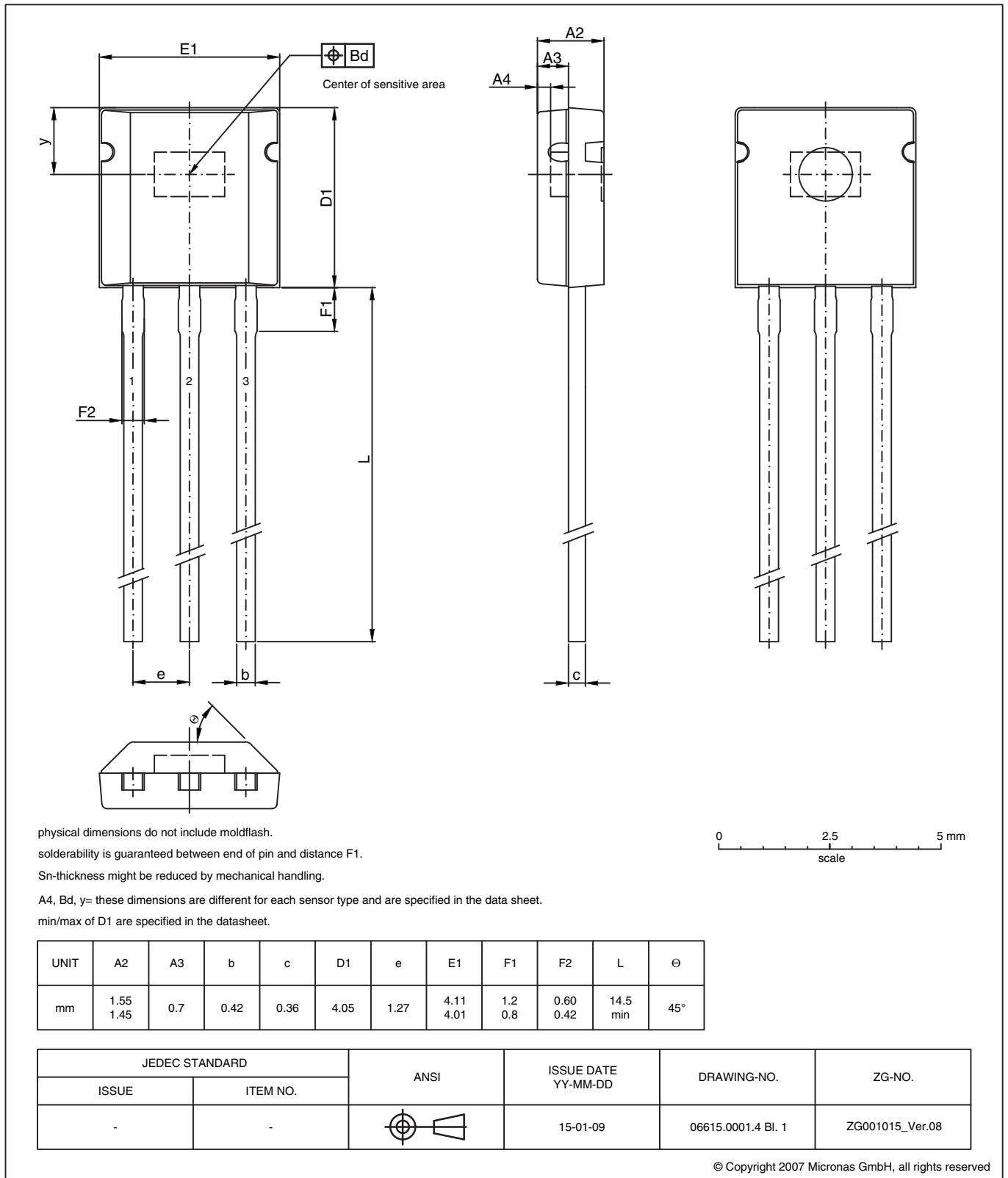

Fig. 4-1:
TO92UT-2 Plastic Transistor Standard UT package, 3 pins
 Weight approximately 0.12 g

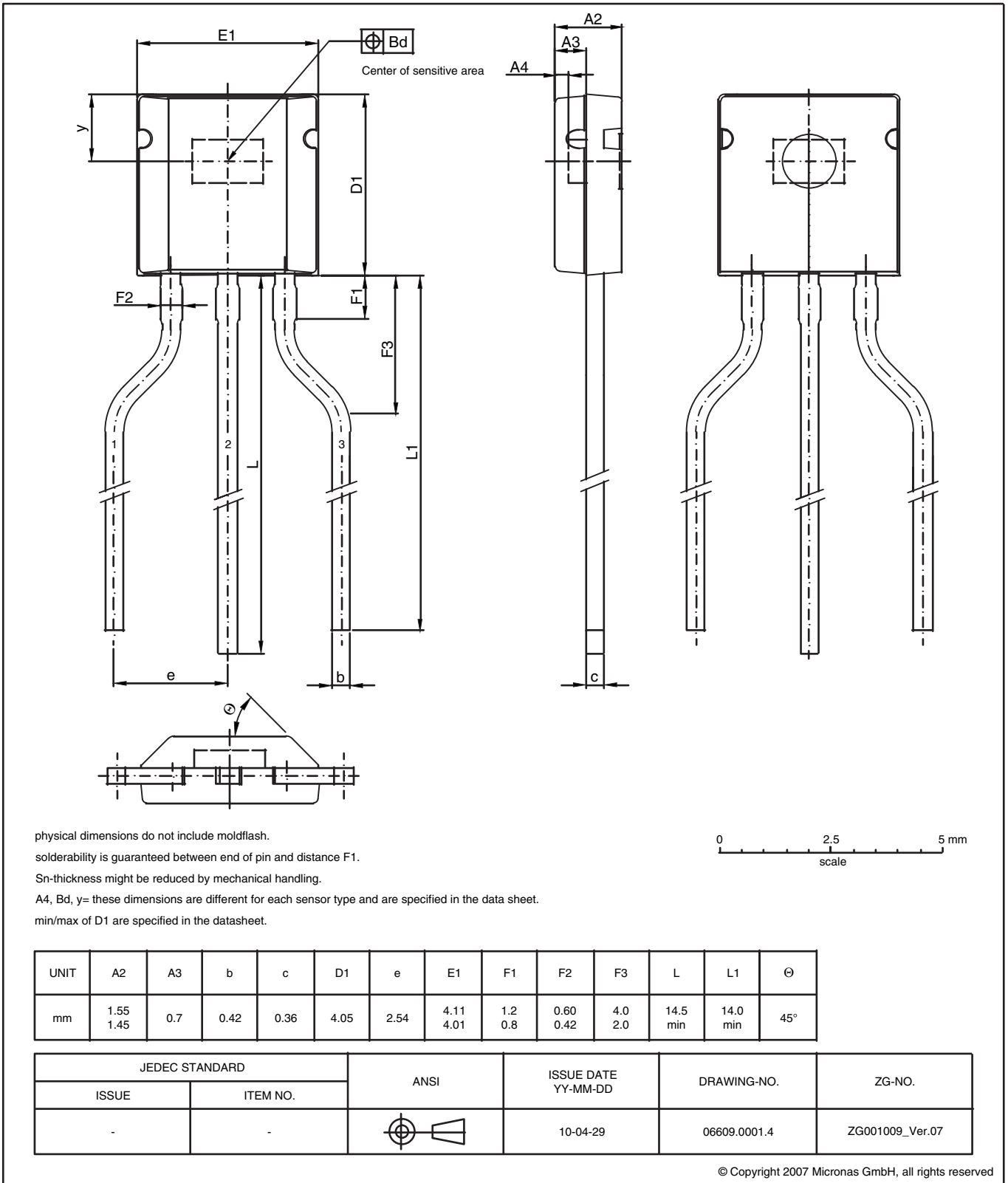

Fig. 4-2:
TO92UT-1 Plastic Transistor Standard UT package, 3 leads, spread
 Weight approximately 0.12 g

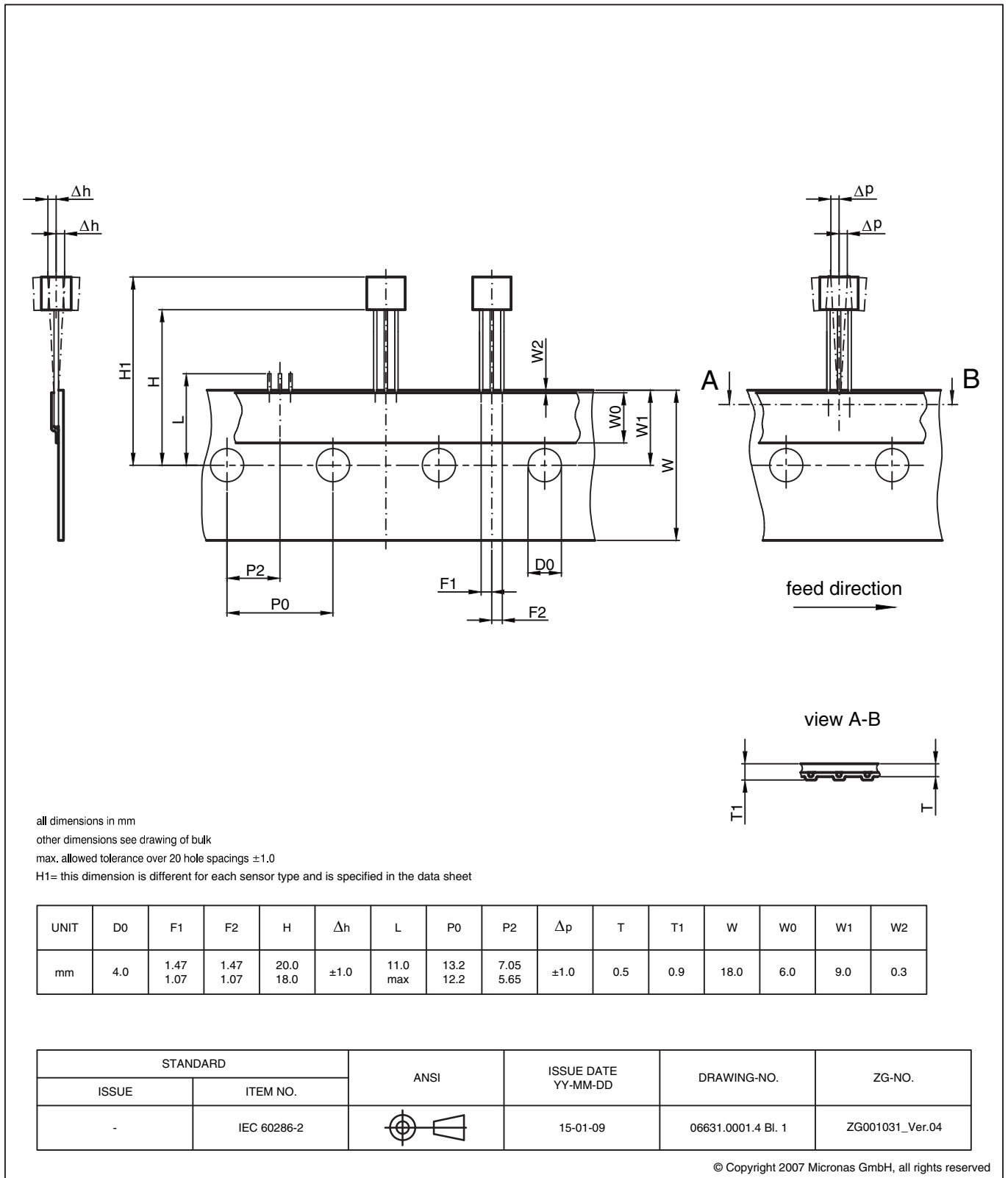
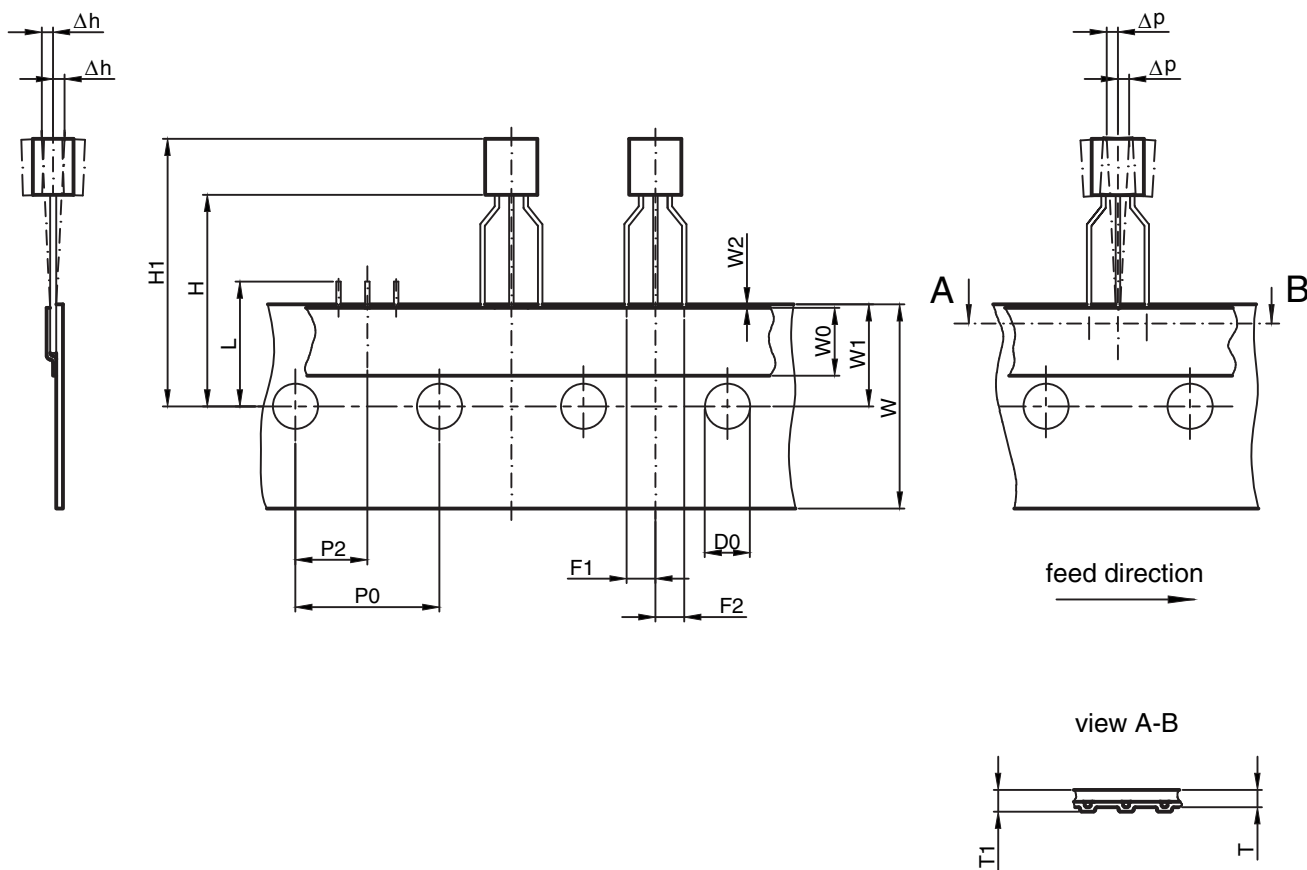

Fig. 4-3:
TO92UA/UT: Dimensions ammpack inline, not spread, standard lead length



all dimensions in mm
 other dimensions see drawing of bulk
 max. allowed tolerance over 20 hole spacings ±1.0
 H1= this dimension is different for each sensor type and is specified in the data sheet

UNIT	D0	F1	F2	H	Δh	L	P0	P2	Δp	T	T1	W	W0	W1	W2
mm	4.0	2.74 2.34	2.74 2.34	20.0 18.0	±1.0	11.0 max	13.2 12.2	7.05 5.65	±1.0	0.5	0.9	18.0	6.0	9.0	0.3

JEDEC STANDARD		ANSI	ISSUE DATE YY-MM-DD	DRAWING-NO.	ZG-NO.
ISSUE	ITEM NO.				
-	ICE 60286-2		15-01-09	06632.0001.4 Bl. 1	ZG001032_Ver.05

© Copyright 2007 Micronas GmbH, all rights reserved

Fig. 4-4:
TO92UA/UT: Dimensions ammpack inline, spread, standard lead length

4.2. Soldering, Welding and Assembly

Information related to solderability, welding, assembly, and second-level packaging is included in the document “Guidelines for the Assembly of Micronas Packages”. It is available on the Micronas website (<http://www.micronas.com/en/service-center/downloads>) or on the service portal (<http://service.micronas.com>).

4.3. Pin Connections and Short Descriptions

Pin No.	Pin Name	Type	Short Description
1	VSUP		Supply Voltage
2	GND		Ground
3	DIO	IN/ OUT	Digital IO SENT Output

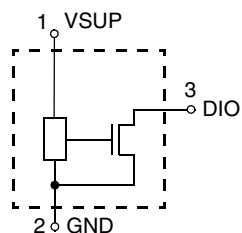

Fig. 4-5: Pin configuration

4.4. Dimensions of Sensitive Area

0.213 mm x 0.213 mm

4.5. Positions of Sensitive Area

	T092UT-1/-2
A4	0.4 mm
Bd	0.3 mm
D1	4.05 ±0.05 mm
H1	min. 22.0 mm, max. 24.1 mm
y	1.55 mm nominal

4.6. Absolute Maximum Ratings

Stresses beyond those listed in the “Absolute Maximum Ratings” may cause permanent damage to the device. This is a stress rating only. Functional operation of the device at these conditions is not implied. Exposure to absolute maximum rating conditions for extended periods will affect device reliability.

This device contains circuitry to protect the inputs and outputs against damage due to high static voltages or electric fields; however, it is advised that normal precautions be taken to avoid application of any voltage higher than absolute maximum-rated voltages to this high-impedance circuit.

All voltages listed are referenced to ground (GND).

Symbol	Parameter	Pin Name	Min.	Max.	Unit	Comment
T _J	Junction Operating Temperature	–	–40	190 ¹⁾	°C	not additive
V _{SUP}	Supply Voltage	VSUP	–18	26.5 ²⁾ 40 ³⁾	V V	not additive not additive
V _{DIO}	IO Voltage	DIO	–0.5	26.5 ²⁾	V	not additive
B _{max}	Magnetic field	–	–	unlimited	T	
V _{ESD}	ESD Protection	VSUP, DIO	–8.0 ⁴⁾	8.0 ⁴⁾	kV	
¹⁾ for 96h. Please contact Micronas for other temperature requirements ²⁾ t < 5 min. ³⁾ t < 5 x 500 ms ⁴⁾ AEC-Q100-002 (100 pF and 1.5 kΩ)						

4.6.1. Storage and Shelf Life

Information related to storage conditions of Micronas sensors is included in the document “Guidelines for the Assembly of Micronas Packages”. It gives recommendations linked to moisture sensitivity level and long-term storage.

It is available on the Micronas website (<http://www.micronas.com/en/service-center/downloads>) or on the service portal (<http://service.micronas.com>).

4.7. Recommended Operating Conditions

Functional operation of the device beyond those indicated in the “Recommended Operating Conditions/Characteristics” is not implied and may result in unpredictable behavior, reduce reliability and lifetime of the device.

All voltages listed are referenced to ground (GND).

Symbol	Parameter	Pin Name	Min.	Max.	Unit	Remarks
V _{SUP}	Supply Voltage	VSUP	4.5	17	V	
V _{DIO}	Output Voltage	DIO	0	18	V	
I _{OUT}	Continuous Output Current	DIO	–	20	mA	for V _{DIO} = 0.6 V
V _{Pull-Up}	Pull-Up Voltage	DIO	3.0	18	V	In typical applications V _{Pull-Up, max} = 5.5 V
R _{Pull-Up}	Pull-Up Resistor	DIO	(see Section 7.3. on page 32)			
1) Depends on the temperature profile of the application. Please contact Micronas for life time calculations.						
C _L	Load Capacitance	DIO	180	(see Section 7.3. on page 32)	pF	
N _{PRG}	Number of EEPROM Programming Cycles	–	–	100	cycles	0 °C < Tamb < 55 °C
T _J	Junction Operating Temperature ¹⁾	–	–40 –40 –40	125 150 170	°C °C °C	for 8000h (not additive) for 2000h (not additive) < 1000h (not additive)
1) Depends on the temperature profile of the application. Please contact Micronas for life time calculations.						

4.8. Characteristics

at T_J = 40 °C to +170 °C (for temperature type A), V_{SUP} = 4.5 V to 17 V, GND = 0 V,
at Recommended Operation Conditions if not otherwise specified in the column Conditions.
Typical Characteristics for T_J = 25 °C and V_{SUP} = 5 V..

Symbol	Parameter	Pin Name	Min.	Typ.	Max.	Unit	Conditions
I _{SUP}	Supply Current	VSUP	–	12	17	mA	
I _{DIOH}	Output Leakage Current	DIO	–	–	10	µA	
V _{SUPon}	Power-On Reset Level	VSUP	3.7	4.15	4.45	V	
V _{SUPonHyst}	Power-On Reset Level Hysteresis	VSUP	–	0.1	–	V	
V _{SUPOV}	Supply Over Voltage Reset Level	VSUP	17	19.5	21	V	
V _{SUPOVHyst}	Supply Over Voltage Reset Level Hysteresis	VSUP	–	0.4	–	V	

Symbol	Parameter	Pin Name	Min.	Typ.	Max.	Unit	Conditions
Digital I/O (DIO) Pin							
V_{OL}	Output Low Voltage	DIO	–	–	0.6 0.2 0.09	V	$I_{OL} = 20\text{ mA}$ $I_{OL} = 5\text{ mA}$ $I_{OL} = 2.2\text{ mA}$
	Output Resolution	DIO	–	–	16	bit	Depending on programming of the sensor and on sensor type
Out_{noise}	Output noise (rms)	DIO		1	2	LSB_{12}	$B = 0\text{ mT}$, $\pm 100\text{ mT}$ range, $FS = 2\text{ kHz}$, $T_J = 25^\circ\text{C}$
$t_{startup_SP}$	Power-Up Time of the signal processing (VSUP on till end of CRC nibble)	DIO	–	9	10.2	ms	HAL2830 or HAL2831, POST = 0, TICK = 3, FS = 2 kHz
				15	18		HAL2830 or HAL2831, POST = 1 or 5, TICK = 3, FS = 2 kHz
				36	40		HAL2830 or HAL2831, POST = 3 or 7, TICK = 3, FS = 2 kHz
				6.6	7.5		HAL 2832 or HAL2833, POST = 0, HAL 2832 TICK = 3, FS = 2 kHz
				12.5	14		HAL 2832 or HAL2833, POST = 1 or 5, TICK = 3, FS = 2 kHz
				36	40		HAL 2832 or HAL2833, POST = 3 or 7, TICK = 3, FS = 2 kHz
SENT Interface							
$\Delta V/\Delta t_{fall}$	Falling Edge Slew Rate	DIO	1.4	2	2.6	V/ μs	$t_{tick} = 2.00\text{ }\mu\text{s}$ to $2.5\text{ }\mu\text{s}$ Measured between 70% and 30%, $V_{PULL-UP} = 5\text{ V}$, $R_{PULL-UP} = 1\text{ k}\Omega$, $C_L = 470\text{ pF}$
			0.7	1	1.3		$t_{tick} = 2.75\text{ }\mu\text{s}$ to $17.8\text{ }\mu\text{s}$ Measured between 70% and 30%, $V_{PULL-UP} = 5\text{ V}$, $R_{PULL-UP} = 1\text{ k}\Omega$, $C_L = 1\text{ nF}$
$\Delta V/\Delta t_{rise}$	Rising Edge Slew Rate	DIO	1.4	2	2.6	V/ μs	$t_{tick} = 2.00\text{ }\mu\text{s}$ to $2.5\text{ }\mu\text{s}$ Measured between 30% and 70%, $V_{PULL-UP} = 5\text{ V}$, $R_{PULL-UP} = 1\text{ k}\Omega$, $C_L = 470\text{ pF}$
			0.35	0.5	0.65		$t_{tick} = 2.75\text{ }\mu\text{s}$ to $17.8\text{ }\mu\text{s}$ Measured between 30% and 70%, $V_{PULL-UP} = 5\text{ V}$, $R_{PULL-UP} = 1\text{ k}\Omega$, $C_L = 1\text{ nF}$
$t_{startup_SENT}$	Power-Up Time of the SENT Interface	DIO	–	0.1	0.2	ms	POST = 0
				8.4	9.5		POST > 0
t_{tick}	Clock Tick Time	DIO	2.00 ¹⁾	–	17.75 ¹⁾	μs	
t_{nlow}	Nibble Low Time ²⁾	DIO	3.00		6.75	t_{tick}	Due to truncation errors, the max. low time may be slightly smaller at some clock tick times.

Symbol	Parameter	Pin Name	Min.	Typ.	Max.	Unit	Conditions
TO92UT Package							
R_{thja}	Thermal resistance Junction to Ambient	–	–	–	235	K/W	measured on 1s0p board
R_{thjc}	Junction to Case	–	–	–	61	K/W	measured on 1s0p board
R_{thjs}	Junction to Solder Point	–	–	–	128	K/W	measured on 1s1p board
1) Clock tolerance of $\pm 10\%$ is not included 2) The values do not consider the fall and rise time at the output							

4.9. Magnetic Characteristics

at $T_J = 40\text{ °C}$ to $+170\text{ °C}$, $V_{SUP} = 4.5\text{ V}$ to 17 V , $GND = 0\text{ V}$,
 at Recommended Operation Conditions if not otherwise specified in the column Conditions.
 Typical Characteristics for $T_J = 25\text{ °C}$ and $V_{SUP} = 5\text{ V}$.

Symbol	Parameter	Pin Name	Min.	Typ.	Max.	Unit	Conditions
$RANGE_{ABS}$	Absolute Magnetic Range of A/D Converter	–	60	100	110	%	% of nominal RANGE Nominal RANGE programmable from $\pm 40\text{ mT}$ up to $\pm 160\text{ mT}$
INL	Full Scale Non-Linearity	DIO	-0.25	0	0.25		% of full-scale RANGE = 1 ($\pm 40\text{ mT}$)
			-0.15	0	0.15		% of full-scale RANGE ≥ 2 ($\geq \pm 60\text{ mT}$)
ES	Sensitivity Error over Junction Temperature Range	DIO	-1	0	1	%	$T_J = -40$ to 120 °C (see Section 4.9.1.)
			-1.5	0	1.5	%	$T_J = 120$ to 170 °C (see Section 4.9.1.)
B_{OFFSET}	Magnetic Offset	DIO	-0.4	0	0.4	mT	$B = 0\text{ mT}$, $T_A = 25\text{ °C}$ RANGE 80 mT
ΔB_{OFFSET}	Magnetic Offset Drift over Temperature Range $B_{OFFSET}(T) - B_{OFFSET}(25\text{ °C})$	DIO	-5	0	5	$\mu\text{T}/\text{°C}$	$B = 0\text{ mT}$ RANGE 80 mT

4.9.1. Definition of Sensitivity Error ES

ES is the maximum of the absolute value of the quotient of the normalized measured value¹⁾ over the normalized ideal linear²⁾ value minus 1:

$$ES = \max \left(\text{abs} \left(\frac{\text{meas}}{\text{ideal}} - 1 \right) \right) \Big|_{[T_{Jmin}, T_{Jmax}]}$$

In the example shown in Fig. 4–6 the maximum error occurs at -10 °C:

- 1) normalized to achieve a least-squares method straight line that has a value of 1 at 25 °C
- 2) normalized to achieve a value of 1 at 25 °C

$$ES = \frac{1.001}{0.993} - 1 = 0.8\%$$

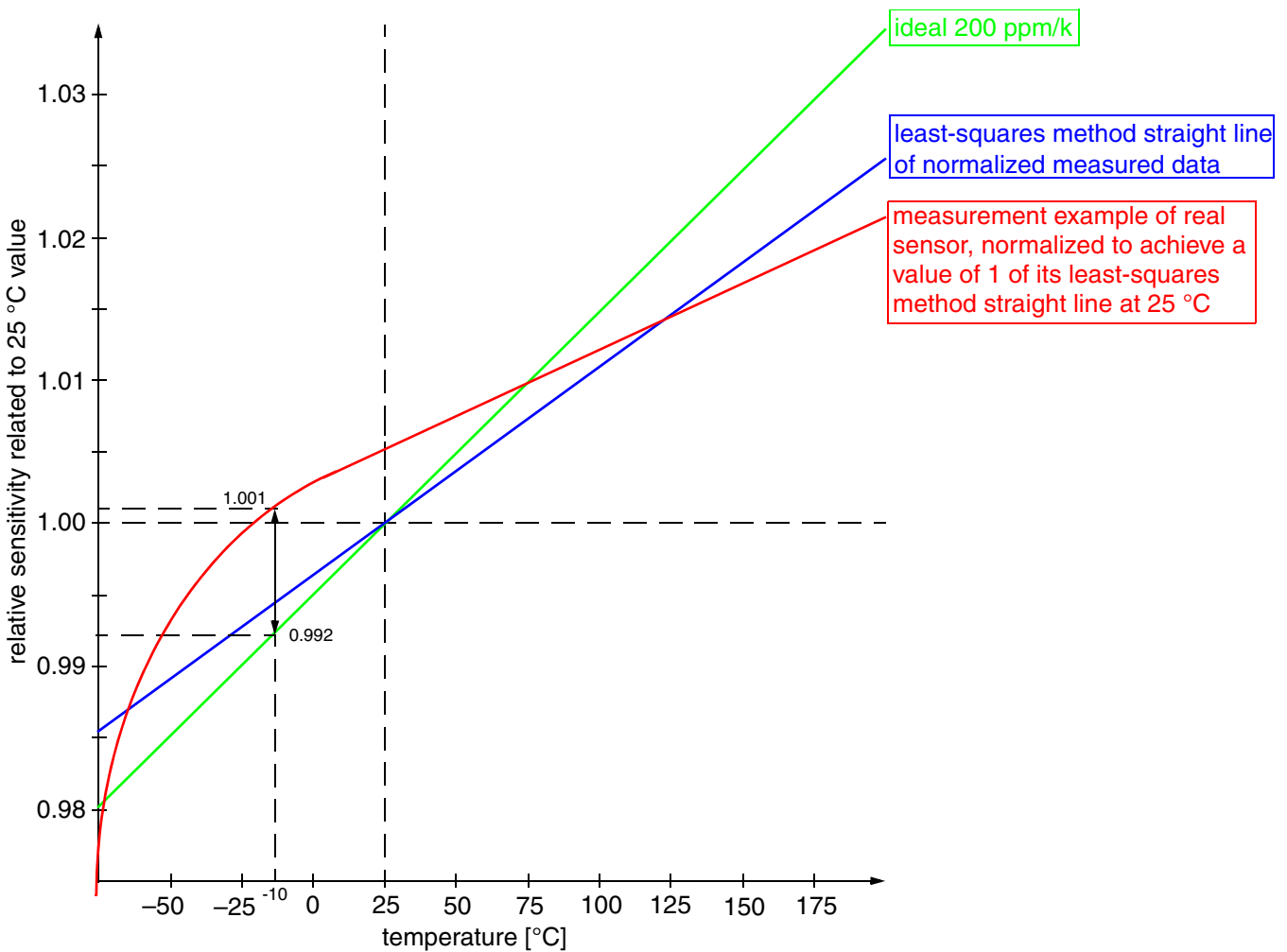

Fig. 4–6: Definition of sensitivity error (ES)

5. The SENT Module

Sensors of the HAL 283x family transmit information by means of SENT data frames. SENT is a unidirectional communication from the sensor to a receiver module (e.g an Electronic Control Unit). It occurs independently of any action of the receiver module, does not require any synchronization signal from the

receiver module and does not include a coordination signal from the controller/receiving device. The signal is transmitted by the sensor as a series of pulses and data is measured as falling to falling edge times. SENT data frames are formatted according to Table 5–1.

Table 5–1: Nibble / period description

#	Period	Number of Clock Ticks		Description
		min.	max.	
1	Synchronization/ Calibration	56		It is mandatory to measure the synchronization / calibration period for calibration of the clock tick time t_{tick} at the ECU.
2	4-bit Status & Communication Nibble	12	27	Bit 0: SPS.RDBL (Hall sample has been already transmitted) Bit 1: MDS.PTO (Power on test is operating) Bit 2: Serial message data bit (See SAE-J2716) Bit 3: Serial message start (See SAE-J2716)
3	4-bit Data Nibble 1			HVAL[15:12]
4	4-bit Data Nibble 2			HVAL[11:8]
5	4-bit Data Nibble 3			HVAL[7:4]
– / 6	4-bit Data Nibble 4 (optional)			HVAL[3:0] Only in case of HAL2831/HAL2833
6 / 7	4-bit CRC			Checksum of data nibble 1 to data nibble 4. See SAE-J2716 2010-01 for more information.
– / 7 / 8	Pause Period (optional)	12 ¹⁾	768 ¹⁾	Only for HAL 2832/HAL2833

¹⁾ Value depends on the selected sample frequency. Mentioned values are the limits of the SAE J2716 2010-01

5.1. Serial data messages (short format)

In addition to the magnetic field information, transmitted by 3 or 4 data nibbles according to sensor’s resolution, other information is transmitted in the status nibble by serial data messages (short format). Serial messages, communicated in a 16-bit sequence, are transmitted by bit 2 and 3 of the Status and Communication nibble (slow channel signals).

Bit 3 is used to notify the start of a serial message (set to 1 at the start of the message, reset to 0 in the successive 15 frames). Bit 2 reproduces the serial transmitted data in the order Most Significant Bit to Least Significant Bit.

The 16-bit serial message is made of a 4-bit Message ID nibble, 2 nibbles (1 byte) of data, and a 4-bit CRC checksum nibble (derived from the Message ID and the 2 data nibbles according to the same checksum algorithm as used to calculate the SENT CRC). The Message ID identifies the type of data being communi-

cated in the Data Byte. Table 5–2 lists the IDs and the related data content. The IDs are continuously transmitted from the lowest ID to highest ID. Refers to SAE-J2716 for more information about the short serial data message format.

Table 5–2: Serial message content

ID	Content	Remark
0	SN[7:0]	Serial Number, byte 1
1	SN[15:8]	Serial Number, byte 2
2	SN[23:16]	Serial Number, byte 3
3	SN[31:24]	Serial Number, byte 4
4	TVAL[7:0]	Temperature value data register. High byte must be captured when low byte is read for transmission.
5	TVAL[15:8]	

Table 5–2: Serial message content

ID	Content	Remark
6	SPE	Signal path status register
7	DS	Device status register
8	PTE	Power-on test error register
9	SYSClk[7:0]	System clock, byte 1
10	SYSClk[15:8]	System clock, byte 2

Registers are commonly defined within the Application Note “HAL 283x Programming Guide”. For better understanding the description of the serial message related registers SPE, DS and PTE is repeated below.

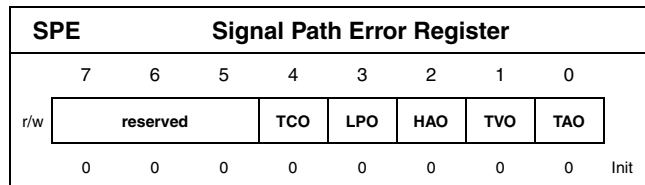

TAO Temperature Sensor ADC Overflow

1: An overflow has occurred.
0: No error

TVO TVAL Calculation Overflow

1: An overflow has occurred.
0: No error

HAO Hall ADC Overflow

1: An overflow has occurred.
0: No error

LPO Low Pass Filter Overflow

1: An overflow has occurred.
0: No error

TCO Temperature Compensation Overflow

1: An overflow has occurred.
0: No error

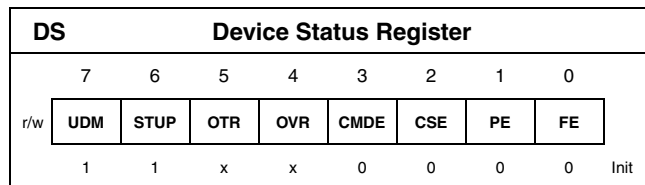

FE Frame Error

1: A frame error has occurred.
0: No error

PE Parity Error

1: A parity error has occurred.
0: No error

CSE Checksum Error

1: A checksum error has occurred.
0: No error

CMDE Command Error

1: A command error has occurred.
0: No error

OVR Overvoltage Reset

1: An overvoltage reset has occurred.
0: No reset

OTR Overtemperature Reset

1: An overtemperature reset has occurred.
0: No reset

STUP Startup

1: A reset has occurred.
0: No reset has occurred.

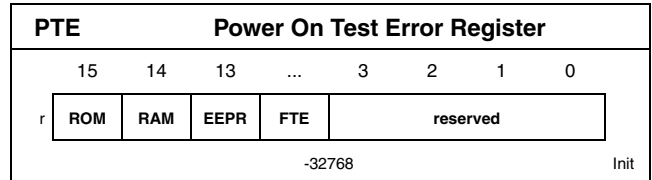

FTE Fluxless Test Error

1: The fluxless test has failed.
0: No error

EEPR EEPROM Error

1: The EEPROM test has failed.
0: No error

RAM RAM Error

1: A RAM test has failed.
0: No error

ROM ROM Error

1: A ROM test has failed.
0: No error

5.2. SENT Message Timing

Fig. 5–1 shows the SENT interface startup timing. After reset the sensor’s output is high. The transmission of SENT messages starts immediately after the SENT transmitter is ready (see $t_{startup_SENT}$ in Section 4.8.). The start-up of the signal processing takes longer than the start-up time of the SENT transmitter,

therefore the first valid Hall value will be calculated after the transmission has been started (see $t_{startup_SP}$ in Section 4.8.). Thus with the first messages the initial value of HVAL (0x800 = low clamp) is transmitted. Valid hall samples are then transmitted as soon as available.

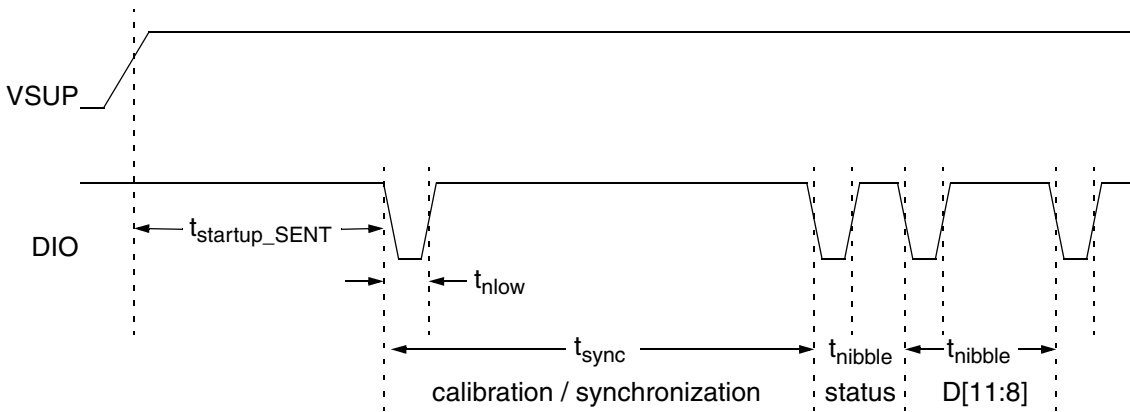

Fig. 5–1: SENT interface startup timing of HAL 283x

The message time of a SENT message depends on the configured tick time, the transmitted data value and the presence of a pause period.

The SENT clock tick time can be configured by the EEPROM bit field TICK, being:

$$t_{tick} = (8 + TICK) \times 0.25 \mu s$$

and

$$TICK = 0 \dots 63$$

The low time can be configured by the EEPROM bit field LT, being:

$$t_{nlow} = \text{trunc}(3 + LT/4) t_{tick}$$

The adjusted slew rate depends on the SENT clock tick time (see Section 4.8. on page 20).

The settings for LT and t_{nlow} that guaranty compliance to SAE-J2716 are shown in Table 5–3.

Table 5–3: Recommended settings for SAE-J2716 compliance.

TICK	t_{tick}	Min. Recommended Low Time		Max. Recommended Low Time	
	typ.	LT	t_{nlow}	LT	t_{nlow}
[LSB]	[μs]	[LSB]	[t_{tick}]	[LSB]	[t_{tick}]
3	2.75	4	4.00	11	5.73
4	3.00			13	6.25
5	3.25			14	6.46
6	3.50			15	6.71
8	4.00				6.75
12	5.00				6.75
63	17.75				6.75

5.2.1. HAL2830/HAL2831 message timing (no pause period)

Fig. 5–2 represents a SENT data frame with three data nibbles for sensors with no pause period. The timing of a SENT message with four data nibbles is similar, with

the fourth data nibble inserted between the third data nibble and the CRC nibble.

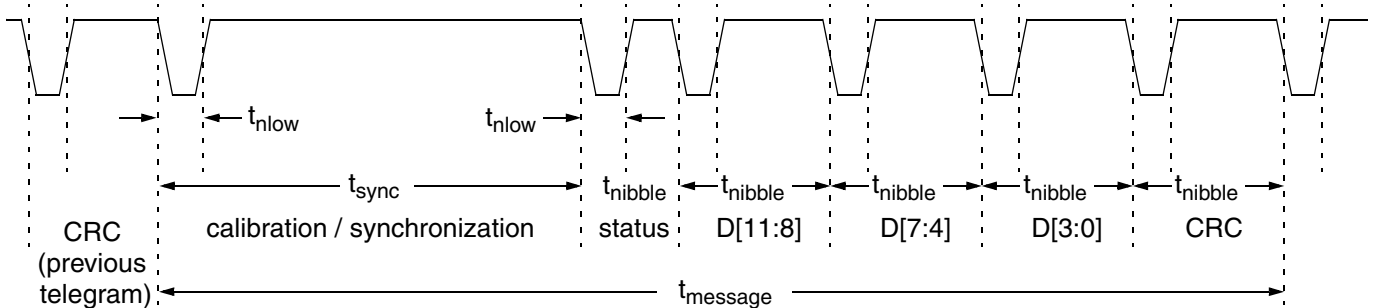

Fig. 5–2: SENT interface timing in case of HAL2830/HAL2831

The SENT messages are transmitted asynchronously to the Hall samples.

The tick times must be properly selected: Hall samples may be lost and aliasing may occur if too slow tick times are chosen. The sample frequency will limit the choices for the clock tick time (see Table 5–4 for HAL2830 and Table 5.2.2. for HAL2831).

For devices with no pause period, even when the recommended tick times is used, samples may be transmitted twice in series due to the fact that the mean message time is shorter than the Hall sample time. A RDBL (read double) flag has been implemented for marking messages which does not contain a new Hall sample. The RDBL flag is located in the register SPS and is transmitted by the status and communication nibble.

Table 5–4: HAL2830 recommended clock time vs. sample frequency

TICK	$t_{tick}^{1)}$	Recommended Sample Frequency
[LSB]	[μ s]	[Hz]
0	2.00	31 to 2000
1	2.25	
2	2.50	
3	2.75	31 to 1000
4	3.00	
8	4.00	
12	5.00	
13	5.25	31 to 500
14	5.50	
35	10.75	
36	11.00	31 to 250
63	17.75	

¹⁾ Clock tolerance of $\pm 10\%$ is not included

Table 5–5: HAL2831 recommended clock time vs. sample frequency.

TICK	$t_{tick}^{1)}$	Recommended Sample Frequency
[LSB]	[μs]	[Hz]
0	2.00	31 to 2000
1	2.25	
2	2.50	31 to 1000
3	2.75	
4	3.00	
8	4.00	
10	4.50	
11	4.75	31 to 500
12	5.00	
29	9.25	
30	9.50	31 to 250
63	17.75	

¹⁾ Clock tolerance of $\pm 10\%$ is not included

5.2.2. HAL 2832/HAL2833 message timing (with pause period)

Fig. 5–3 represents a SENT data frame with three data nibbles for sensors with pause period. The timing of a SENT message with four data nibbles is similar, with the fourth data nibble inserted between the third data nibble and the CRC nibble.

The delivery of new Hall samples is synchronous with the SENT messages, i.e. one SENT message is transmitted per Hall sample. Thus, the propagation delay is very low and the message time is nearly constant. The RDBL (read double) flag has not meaning for devices with pause period. The tick times must be properly selected based on the sample frequency (see Table 5–6 for HAL 2832 and Table 5–7 for HAL2833). The usage of tick times slower than recommended may lead to corrupted SENT messages. The usage of tick times faster than recommended may lead to a pause period which exceeds the limit certified in SAE-J2716 2010-01.

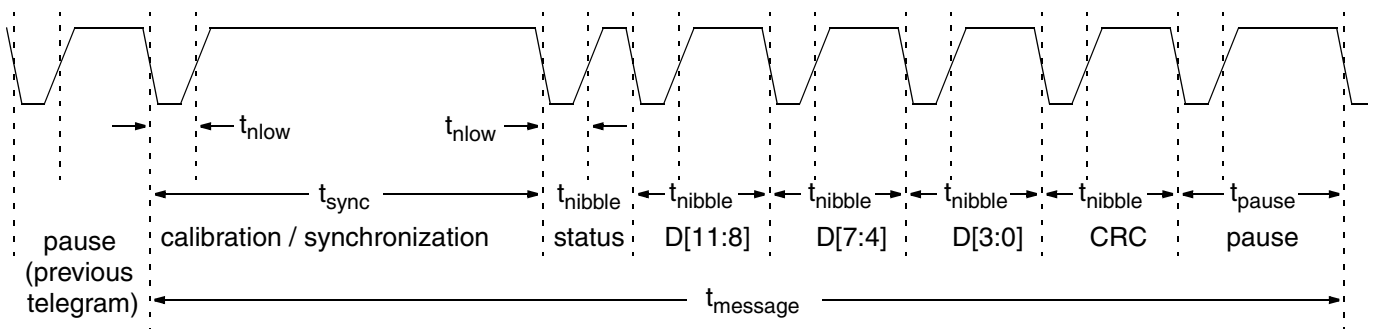

Fig. 5–3: SENT interface timing in case of HAL 2832/HAL2833

Table 5–6: HAL 2832 recommended clock time vs. sample frequency

TICK	t _{tick}	Recommended Sample Frequency
[LSB]	[μs] ¹⁾	[Hz]
0	2.00	1000, 2000
1	2.25	
2	2.50	500, 1000
3	2.75	
4	3.00	
8	4.00	
10	4.5	
11	4.75	250 to 1000
12	5.00	
13	5.25	250, 500
29	9.25	
30	9.50	125 to 500
32	10,00	
33	10.25	125, 250
63	17.75	

¹⁾ Clock tolerance of ±10% is not included

Table 5–7: HAL2833 recommended clock time vs. sample frequency

TICK	t _{tick}	Recommended Sample Frequency
[LSB]	[μs] ¹⁾	[Hz]
0	2.00	1000, 2000
1	2.25	1000
2	2.50	500, 1000
3	2.75	
4	3.00	
8	4.00	
9	4.25	
10	4.50	500
11	4.75	250, 500
12	5.00	
27	8.75	250
29	9.00	
30	9.25	125, 250
63	17.75	

¹⁾ Clock tolerance of ±10% is not included

Note: The length of a message inclusive the pause pulse is equal the sample period. The minimum values for the sample frequency are limited by the maximum pause period length specified in SAE-J2716.

6. Programming of the Sensor

HAL 283x features two different customer modes. In **Application Mode** the sensor provides a continuous SENT data stream. In Programming Mode it is possible to change the register settings of the sensor.

After power-up the sensor is always operating in the **Application Mode**. It is switched to the **Programming Mode** by a defined sequence on the sensor output pin.

6.1. Programming Interface

In Programming Mode the sensor is addressed by modulating a serial telegram (BiPhase-M) with constant bit time on the output pin. The sensor answers with a modulation of the output voltage.

A logical “0” of the serial telegram is coded as no level change within the bit time. A logical “1” is coded as a level change of typically 50% of the bit time. After each bit, a level change occurs (see Table 6–1).

The serial telegram is used to transmit the EEPROM content, error codes and digital values of the magnetic field or temperature from and to the sensor.

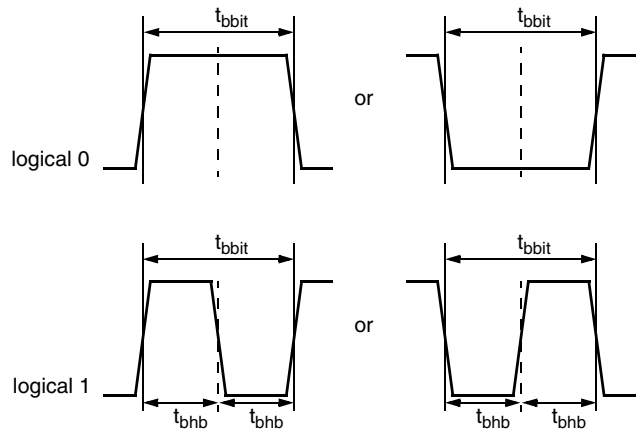

Fig. 6–1: Definition of logical 0 and 1 bit

A description of the communication protocol and the programming of the sensor is available in a separate document (Application Note Programming HAL 283x).

Table 6–1: Biphase-M frame characteristics of the host

Symbol	Parameter	Min.	Typ.	Max.	Unit	Remark
$t_{bbit} (host)$	Biphase Bit Time	970	1024	1075	μs	
$t_{bhb} (host)$	Biphase Half Bit Time	0.45	0.5	0.55	$t_{bbit} (host)$	
$t_{bifsp} (host)$	Biphase Interframe Space	3	–	–	$t_{bbit} (host)$	
V_{rxth_lh}	Receiver low to high threshold voltage	1.2	–	1.5	V	
V_{rxth_hl}	Receiver high to low threshold voltage	1.1	–	1.4	V	
V_{SUPPRG}	Supply Voltage During Programming	5.6	–	6.5	V	

Table 6–2: Biphase-M frame characteristics of the sensor

Symbol	Parameter	Min.	Typ.	Max.	Unit	Remark
$t_{bbit} (sensor)$	Biphase Bit Time	820	1024	1225	μs	
$t_{bhb} (sensor)$	Biphase Half Bit Time	–	0.5	–	$t_{bbit} (sensor)$	
t_{bresp}	Biphase Response Time	1	–	5	$t_{bbit} (sensor)$	
	Slew Rate		2		V/ μs	

6.2. Programming Environment and Tools

For the programming of HAL 283x during product development a programming tool including hardware and software is available on request. It is recommended to use the Micronas tool kit in order to ease the product development. The details of programming sequences are also available on request.

6.3. Programming Information

For production and qualification tests, it is mandatory to set the LOCK bit after final adjustment and programming of HAL 283x. The LOCK function is active after the next power-up of the sensor.

The success of the LOCK process must be checked by reading the status of the LOCK bit after locking and/or by an analog check of the sensors output signal.

Electrostatic Discharge (ESD) may disturb the programming pulses. Please take precautions against ESD and check the sensors error flags.

7. Application Notes

7.1. Ambient Temperature

Due to the internal power dissipation, the temperature on the silicon chip (junction temperature T_J) is higher than the temperature outside the package (ambient temperature T_A).

$$T_J = T_A + \Delta T$$

At static conditions and continuous operation, the following equation applies:

$$\Delta T = I_{SUP} \times V_{SUP} \times R_{thJX} + I_{DIO} \times V_{DIO} \times R_{thJX}$$

For typical values, use the typical parameters. For worst case calculation, use the max. parameters for I_{SUP} and R_{th} , and the max. value for V_{SUP} from the application. The choice of the relevant R_{thJX} parameter (R_{thJa} , R_{thjC} , or R_{thjS}) depends on the way the device is (thermally) coupled to its application environment.

For the HAL 283x, the junction temperature T_J is specified. The maximum ambient temperature T_{Amax} can be calculated as:

$$T_{Amax} = T_{Jmax} - \Delta T$$

7.2. EMC and ESD

For applications that cause disturbances on the supply line or radiated disturbances, a series resistor and a capacitor are recommended. The series resistor and the capacitor should be placed as closely as possible to the Hall sensor.

Please contact Micronas for detailed investigation reports with EMC and ESD results.

7.3. Application Circuit

Micronas recommends the following two application circuits for the HAL 283x.

The external circuit mentioned in Fig. 7–1 is recommended when $V_{BAT} \geq V_{Pull-up}$. It is typically used when the supply pin is directly connected with the battery voltage and the DIO pin operates on a regulated power supply.

Fig. 7–2 shows the recommended circuit according to the SAE-J2716 2010-01. It can be used when $V_{BAT} = V_{Pull-up} < 7$ V. The Pull-up resistor $R_{Pull-up1}$ must be placed close to the sensor to be compliant with the SENT specification. For saving external components, the resistors $R_{Pull-up1}$ and $R_{Pull-up2}$ could be combined to $R_{Pull-up}$ and placed close to the ECU. This might be possible for some applications only and will not be compliant with the SENT specification.

The electrical characteristics mentioned in Section 4. (e.g. V_{SUP}) has to be considered at the system setup. They may reduce the operation range.

Values of external components:

$$C_{VSUP} = 47 \text{ nF}$$

$$C_{DIO} = 180 \text{ pF}$$

The maximum allowed load capacitor and the minimum resistance can be calculated with the following equation:

$$C_L = C_{DIO} + C_{wire} + C_{INPUT}$$

$$R_L = R_{Pull-up}$$

$$R_L \geq \frac{V_{Pull-up(max)} - V_{DIO(L(max))}}{I_{DIO} - (C_L \times (\Delta V / \Delta t_{fall}))}$$

$$C_L \leq \frac{0.4 \times V_{Pull-up(min)}}{R_L \times (\Delta V / \Delta t_{rise})}$$

$$R_{Pull-up} = R_{Pull-up1} \parallel R_{Pull-up2}$$

- $R_{Pull-up}$: Pull-up resistor between DIO and $V_{Pull-up}$
- C_{VSUP} : Capacitance between the VSUP pin and GND
- C_{DIO} : EMC protection capacitance on the DIO pin
- C_{wire} : Capacity of the wire
- C_{INPUT} : Input capacitance of the ECU
- $V_{Pull-up (max.)}$: Max. applied Pull-up voltage, must be lower than the value specified in section 4.7.
- $V_{Pull-up (min.)}$: Min. applied Pull-up voltage, must be higher than the value specified in section 4.7.
- $V_{DIO(L (max.)}$: Max. DIO low voltage, it is recommended to use the value specified in section 4.8.
- I_{DIO} : DIO current at $V_{DIO(L (max.)}$
- $\Delta V / \Delta t_{rise}$: Selected rising edge slew rate, the max. value specified in section 4.8. has to be used
- $\Delta V / \Delta t_{fall}$: Selected falling edge slew rate, the max. value specified in section 4.8. has to be used

Example for Calculating R_L and C_L (max.)

The application operates at following conditions:
 falling slew rate = 1 V/ μ s (typ.)
 rising slew rate = 0.5 V/ μ s (typ.)
 $V_{Pull-up}$ = 5.5 V (max.)
 C_L = 400 pF

Calculation:

$$R_L \geq \frac{5.5V - 0.8V}{20mA - 400pF \times 1.3V/\mu s} = 241\Omega \quad R_L = 1000\Omega$$

Check C_L :

$$C_L = 400pF \leq \frac{0.4 \times 4.5V}{1000\Omega \times 0.65V/\mu s} = 2.77nF$$

The used C_L is below the limit.

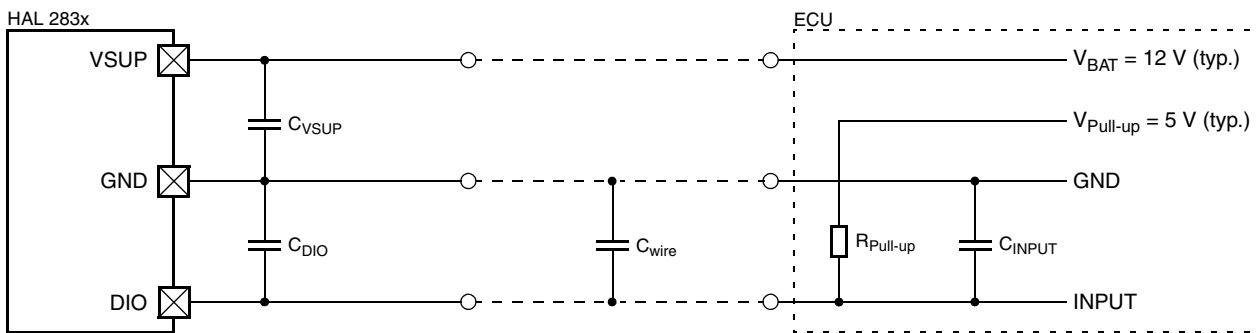

Fig. 7-1: Recommended external circuit for $V_{SUP} \geq V_{Pull-up}$

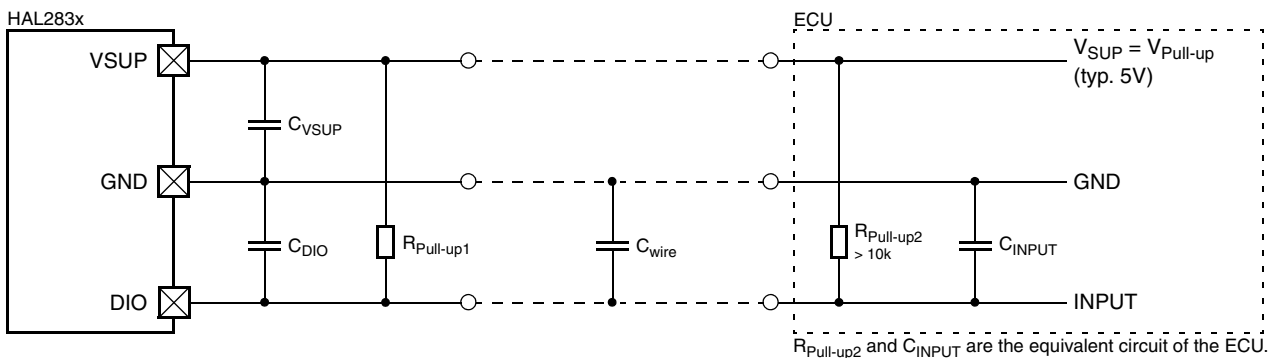

Fig. 7-2: Recommended external circuit for $V_{SUP} = V_{Pull-up} < 7 V$

Note: The external components needed to protect against EMC and ESD may differ from the application circuit shown and have to be determined according to the needs of the application specific environment.

8. Data Sheet History

1. Advance Information: "HAL283x Linear Hall-Effect Sensor Family with SENT Interface", Oct. 9, 2008, AI000143_001EN. First release of the advance information.
2. Advance Information: "HAL283x Linear Hall-Effect Sensor Family with SENT Interface", Sept. 6, 2010, AI000143_002EN. Second release of the advance information.
3. Data Sheet: "HAL 2830, HAL 2831, HAL 2832, HAL 2833 Linear Hall-Effect Sensor Family with SENT Interface", July 4, 2014, DS000165_001EN. First release of the data sheet.
Major change:
 - Chapter 5. "SENT Module" updated
4. Data Sheet: "HAL 283x Linear Hall-Effect Sensor Family with SENT Interface", Jan. 18, 2016, DS000165_002EN. Second release of the data sheet.
Major change:
 - TO92UT-2 package drawing updated
 - Ammopack drawing updated
 - Magnetic Characteristics: Sensitivity Error over Junction Temperature Range (ES) values changed